



# REAR BUMPER

## FOR RAM HD TRUCKS

### PLEASE READ BEFORE YOU START

To guarantee a quality installation, we recommend reading these instructions thoroughly before beginning any work. These instructions assume a certain amount of mechanical ability and are not written nor intended for someone not familiar with auto repair.

**NOTE:** Pre-2019 trucks will require a wiring extension on the park sense harness if equipped. Please see Section III-B, step 4, for more details.

### TABLE OF CONTENTS

- I. Removal of Factory Components
- II. Installation of Blackout Vinyl
- III. Preparing Center Section
- IV. Installing Center Section
- V. Installing Frame Rail Brackets
- VI. Installing Corner Tubes
- VII. Installing Corner Tanks
- VIII. Diesel Exhaust Modification 2019+
- IX. Diesel Exhaust Modification Pre-2019



# REAR BUMPER

RAM HD TRUCK

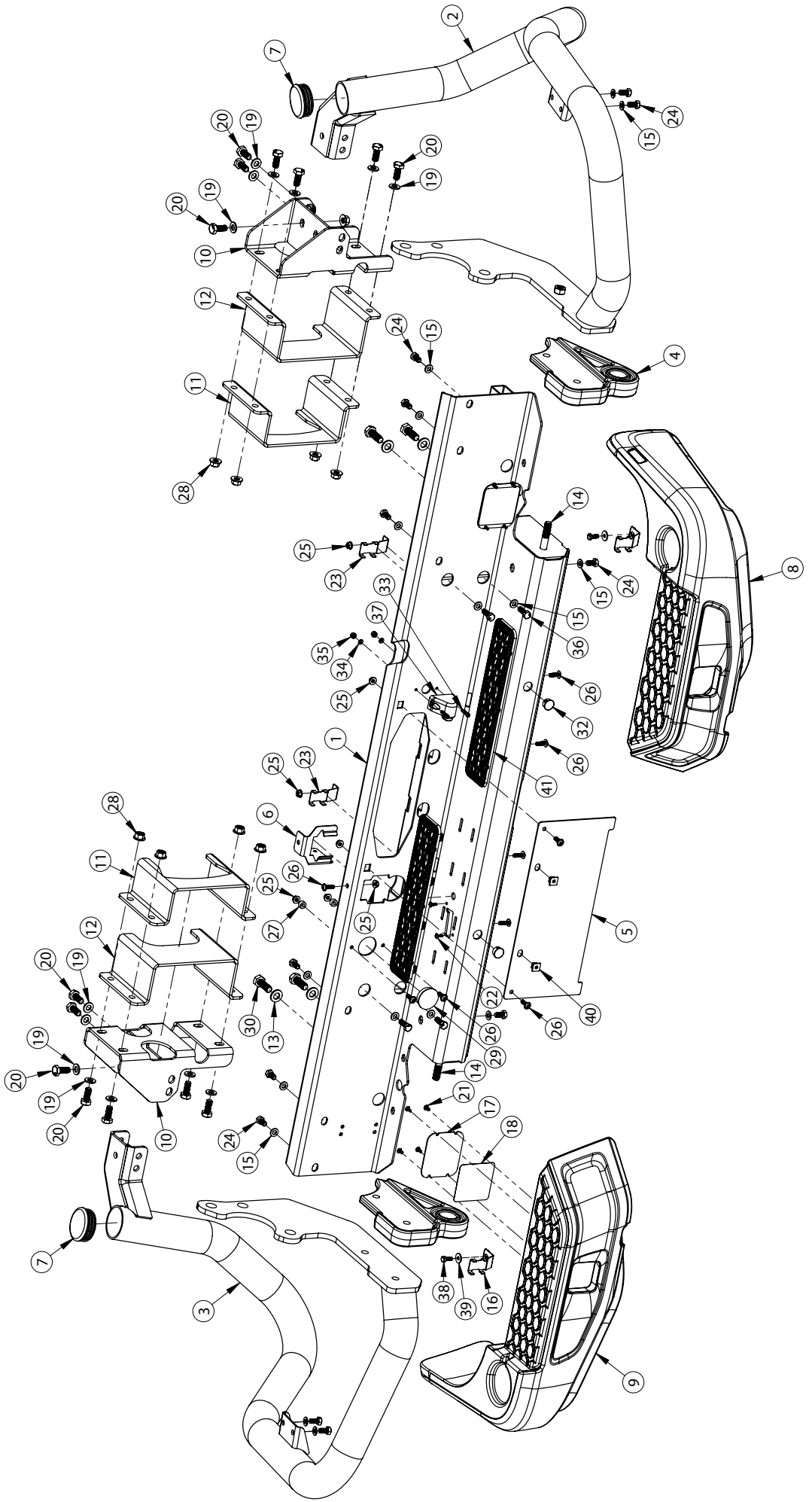



# REAR BUMPER

RAM HD TRUCK

ITEM NO.	PartNo	DESCRIPTION	QTY
1	ARMB0300AB	CENTER SECTION	1
2	ARMB0306AA	CORNER TUBE RH	1
3	ARMB0307AA	CORNER TUBE LH	1
4	ARMB3001AB	TOW LOOP	2
5	ARMB3008AA	LICENSE PLATE ATTACHMENT	1
6	ARMB3009AA	TRAILER PLUG BRACKET	1
7	CCF-2 1/2-8-12	END CAPS	2
8	ARMB3020AA	CORNER TANK RH	1
9	ARMB3021AA	CORNER TANK LH	1
10	ARMB0310AB	OUTBOARD FRAME BRACKET	2
11	ARMB3039AB	INBOARD FRAME BRACKET (LEAF SPRING OPTION)	2
12	ARMB3040AA	INBOARD FRAME BRACKET (COIL SPRING OPTION)	2
13	AEV98004AC	M12 FLAT WASHER	8
14	AEV91065AA	M12 X 1.75 X HEX CAP SCREW	4
15	AEV98007AB	M8 FLAT WASHER	16
16	ARMB3038AA	CORNER PARK SENSOR BRACKET	2
17	ARMB3034AA	TANK CLOSEOUT	2
18	ARMB3035AA	REFLECTOR	2
19	AEV98001AB	M10 FLAT WASHER	14
20	AEV91025AA	M10 X 1.5 HEX HEAD SCREW	14
21	90221A212	PUSH-IN RIVET, NYLON	8
22	4C12KFB1	M4 X 0.7 BUTTON HEAD SCREW	2

ITEM NO.	PartNo	DESCRIPTION	QTY
23	ARMB3049AA	CENTER PARK SENSOR BRACKET	2
24	AEV91024	M8 X 1.25 HEX HEAD BOLT	12
25	AEV93027AA	M6 FLANGE NUT	9
26	AEV91055AA	M6 X 1.0 BUTTON HEAD FLANGED CAP SCREW	9
27	AEV91134AA	SPACER, NYLON	2
28	AEV93002AB	M10 X 1.5 FLANGE NUT	14
29	DOP-1500	DOME PLUG	1
30	AEV91016AA	M12 X 1.75 HEX HEAD SCREW	4
31	AEV91155AA	M4 FLANGE NUT	2
32	85985K19	LOCKING PANEL PLUG	2
33	AEV91152AA	#8-32 X 3/4" SHCS SS	2
34	8NWSFS	#8 FLAT WASHER SS	2
35	8CNINES	#8-32 NYLOCK NUT	2
36	AEV91042AA	M8 X 1.25 BHCS	4
37	LPL12CKM2B	LED LICENSE PLATE LIGHT	1
38	AEV91118AA	M6 X 1.0 HEX HEAD CAP SCREW	2
39	AEV98027AA	M6 FLAT WASHER 18MM OD	2
40	70008123	LICENSE PLATE NUT (NYLON)	2
41	ACP80010AA	MOLDED STEP PAD	2



## I. REMOVAL OF FACTORY COMPONENTS

1. Remove license plate.
2. 2019+ Trucks, disconnect the two electrical connectors located on the driver's side of the bumper (fig. 1).  
2010–2018 Trucks, disconnect the park sense harness, trailer connector, and license plate light.

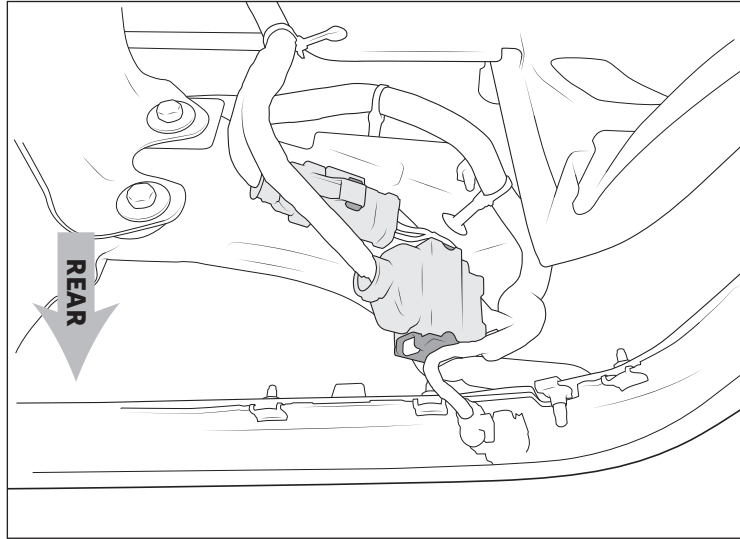

Figure 1

3. On trucks equipped with fifth wheel prep package, disconnect the trailer connector harness from the back of the factory bumper.
4. Remove the two center nuts (fig. 2).

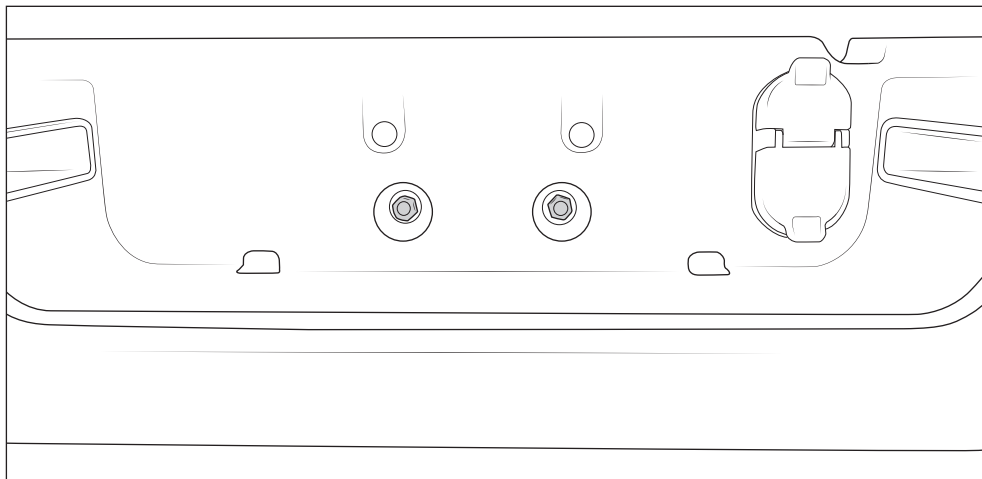
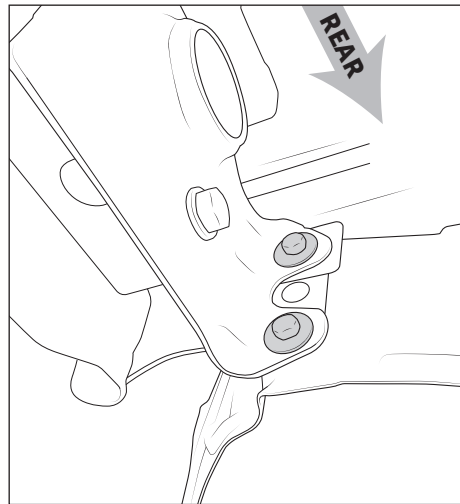

Figure 2



- Support the bumper and remove the two outboard bolts from each side of the main mounting points (fig. 3).



*Figure 3: Driver's Side shown*

- Carefully remove the bumper from the truck, being sure to slide it rearward off the two center studs.
- With the bumper removed, remove and discard the two frame rail end plates shown below (fig. 4).

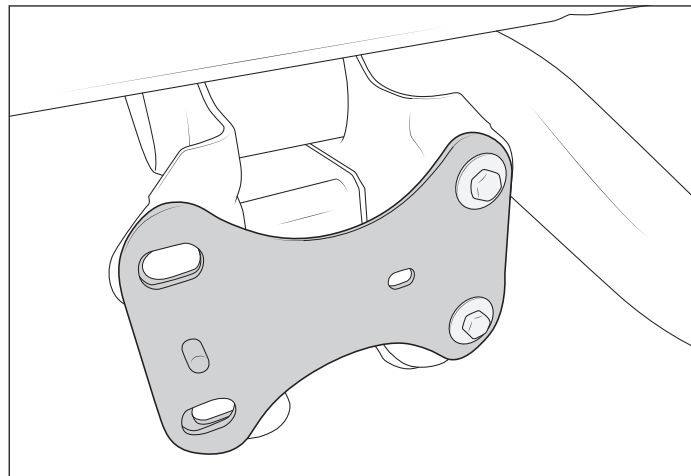

*Figure 4*



## II. INSTALLATION OF BLACKOUT VINYL

NOTE: The provided decals are intended to cover up the section of bedside that will be exposed by the AEV Rear Bumper. Installation is optional but highly recommended.

1. Thoroughly clean the area, including the backside of the bedside where the vinyl wraps around.
2. Tape upper vinyl and carrier into place, using the body line to align the carrier (fig. 5).

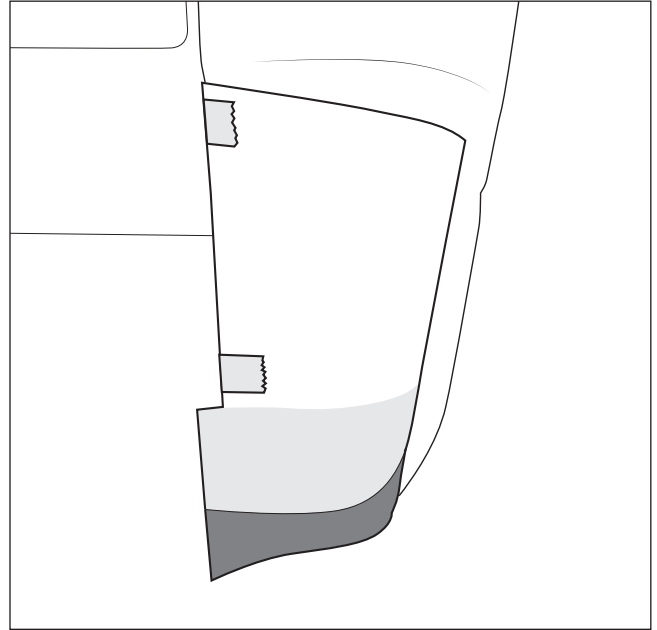
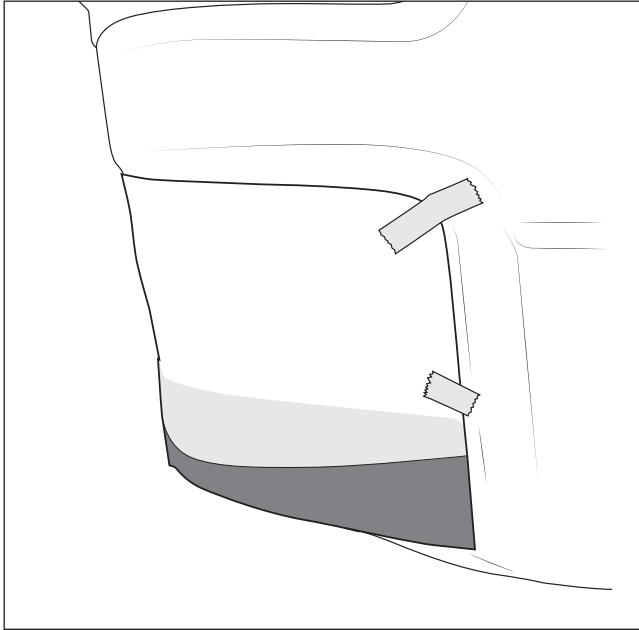

Figure 5

3. Tape lower vinyl into place using the upper vinyl as a locator.
  - A. There should be roughly a 1/4" overlap. Upper vinyl overlapping the lower (fig. 6).
  - B. Make sure that the lower vinyl is positioned high enough to fill the radius shown below (fig. 7).

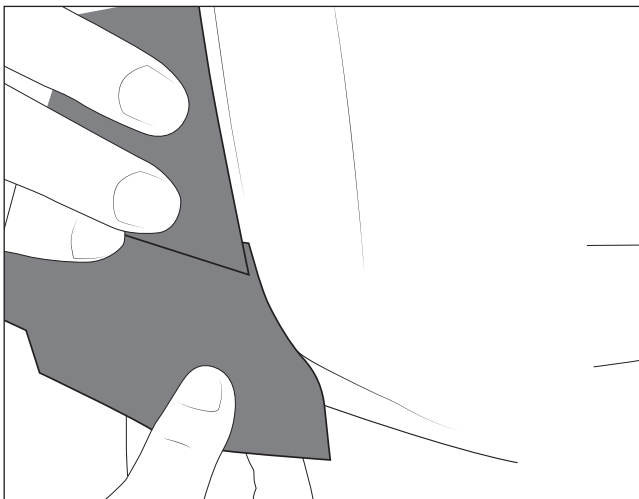

Figure 6

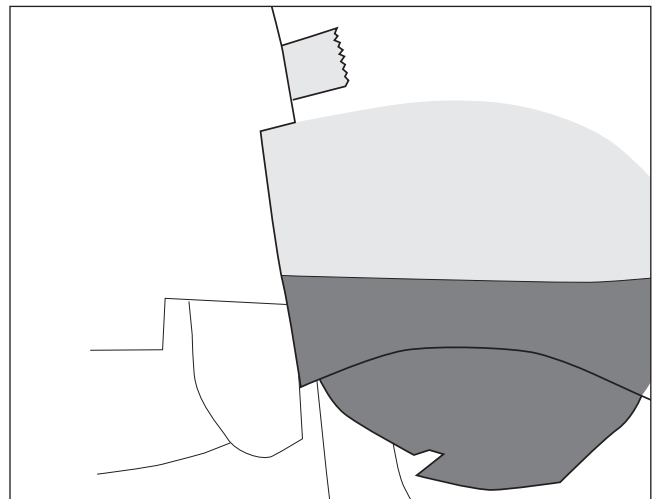
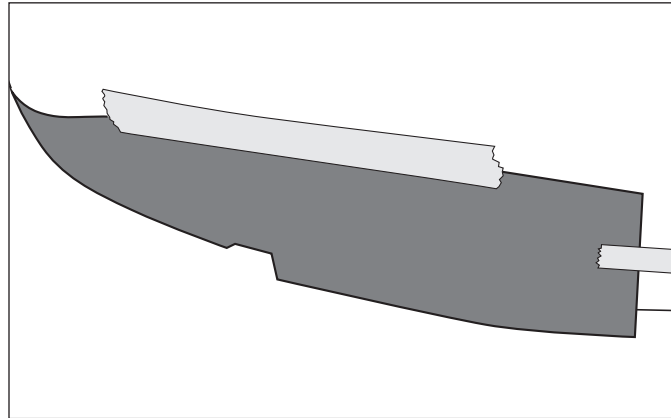

Figure 7



4. Keeping the lower vinyl taped in place, remove the upper vinyl and carrier, these will be installed after the lower.
5. Create a hinge on the lower vinyl using tape as shown below (fig. 8).



*Figure 8*

6. Lift lower piece up, remove backer, and start to install into position.
7. It works best to work top to bottom with a squeegee, pushing and pulling the material toward the bottom of the bedside. NOTE: This vinyl material is not intended to be installed using any lubricant.
8. The rounded corner of the bedside will require the use of a heat gun to help soften and stretch the material around the contour of the bedside without creasing. NOTE: Be careful not to overheat the vinyl material. A low setting and short applications of heat works best.
9. Once the material has been worked around this contour, cut two reliefs in the locations shown below. (fig. 9).

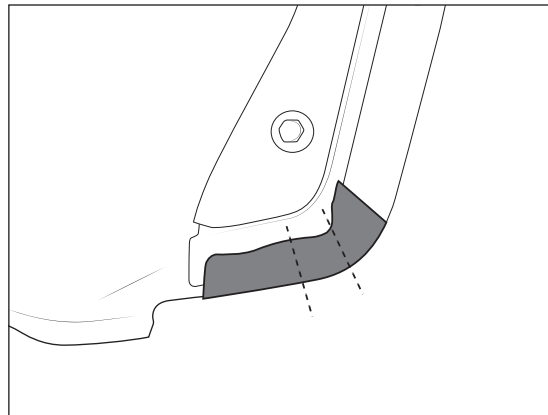
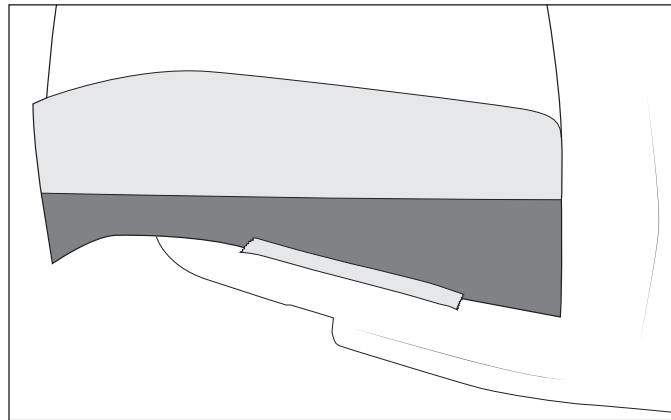

*Figure 9*

10. Wrap the vinyl material around the backside of the sheet metal.
11. On the bottom edge of the bedside, the excess material can be trimmed off.
12. Reinstall the upper vinyl and carrier as detailed in Step 2.



13. Make sure that the upper vinyl is properly aligned with the lower vinyl and is overlapping roughly 1/4 inch over the lower.
14. Create a hinge on the upper vinyl using tape as shown below (fig. 10).



*Figure 10*

15. Remove carrier and backer from upper vinyl and begin to install into position.
16. It works best to work from bottom to top with this vinyl as it is hinged from below.
17. Pull and squeegee the vinyl into position, the heat gun will be needed to help soften and stretch the material around the contour of the back corner.
18. Once the material has been worked to the edges, wrap the excess material around the back of the sheet metal as shown below (fig. 11).

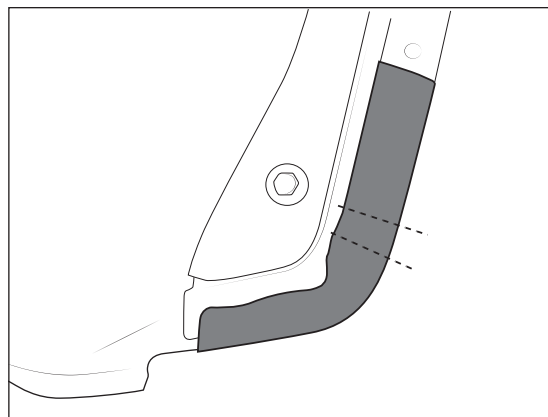

*Figure 11*





### III. PREPARING CENTER SECTION

#### A. Wire Routing for 2019+ Vehicles

1. Remove factory wire harness, trailer connector, and any sensors or modules equipped from stock bumper. It is recommended to label connectors to assist in reinstallation.
2. Position AEV Rear Bumper Center Section face down on a work surface.
3. Begin laying wire harness into position on the AEV Center Section as shown (figure 12). NOTE: Not all trucks will come equipped with all of the shown modules. If your truck does not have one of the modules detailed below, simply disregard and move on to the next step.

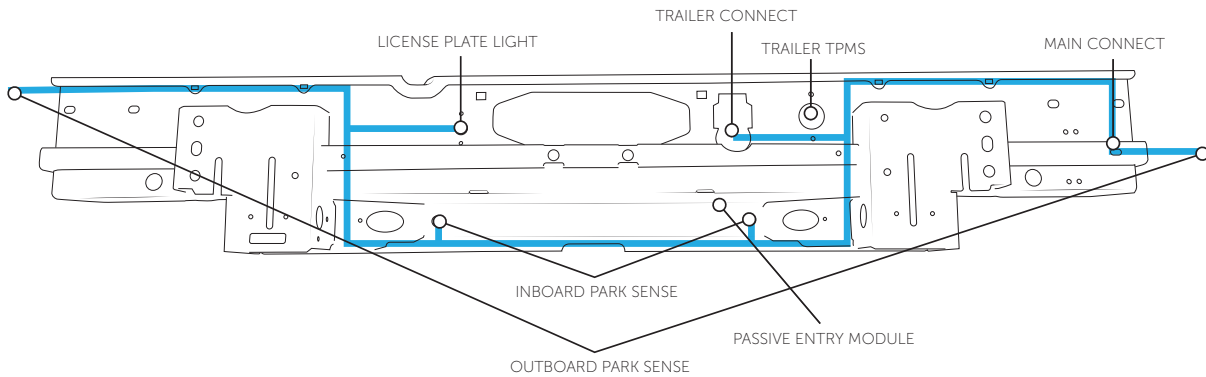

Figure 12

4. Mount the two main factory connectors to the Center Sections mounting locations (fig. 14).

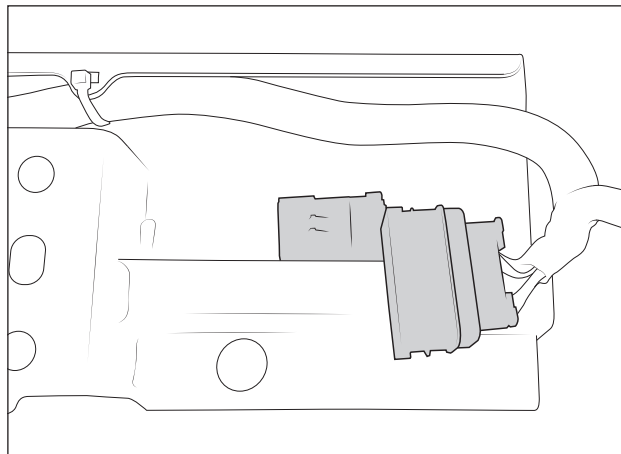
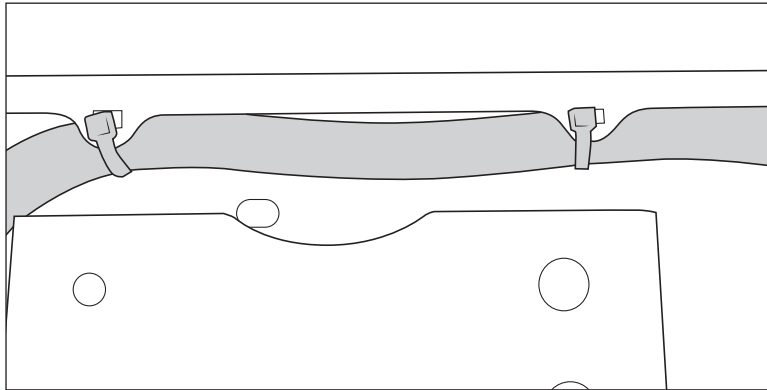

Figure 14



5. Run the factory harness up and over the frame mounting bracket as shown below (fig. 15). Standard zip ties can be used to secure the harness down below the top edge of the bumper.



*Figure 15*

6. The factory harness will continue along the bottom edge of the center section. Install two of the supplied M6x20 button head bolts and nuts in the center positions. Supplied stud mounted zip ties will be used to secure the factory harness to these bolts (fig. 16). Be sure to allow for hitch assembly clearance.

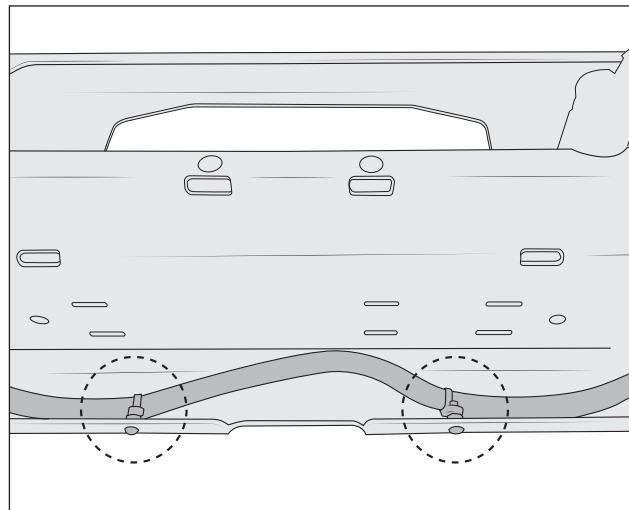

*Figure 16*



## B. Wire Routing for 2010–2018 Vehicles

1. Remove factory wire harness, trailer connector, and park assist sensors from the stock bumper.
2. Position AEV Rear Bumper Center Section face down on a work surface.
3. Lay the harness into position on AEV Center Section placing connectors in locations shown (figure 17).

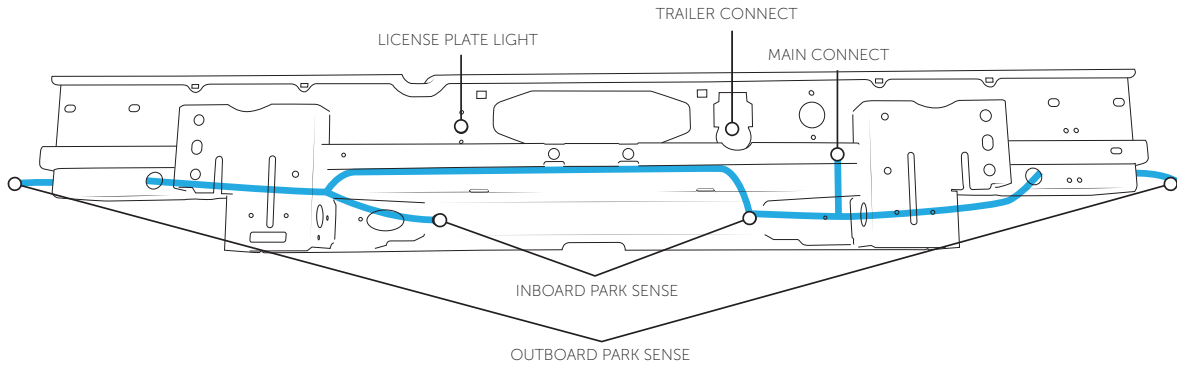

Figure 17

4. The Park Sense harness will need to be lengthened by roughly 9" on the drivers side end of the harness. Use 20 awg wire and solder in the additional wire. Be sure to heat shrink and protect the newly added wire. Secure the park assist harness to the bumper using standard zip ties.

## C. Component Installation

1. Install the included LED license plate light onto Center Section using supplied #8 Allen head bolts, washers, and nuts (fig. 18).

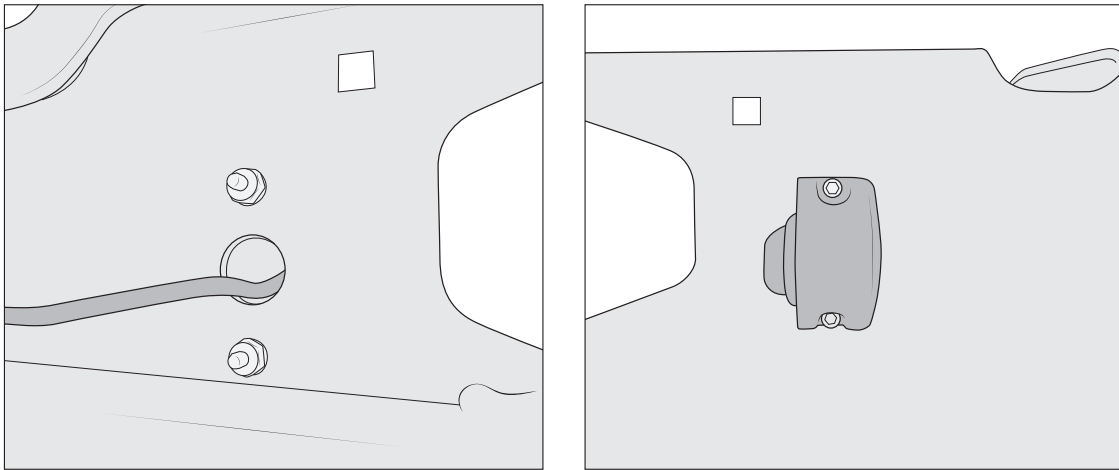

Figure 18: Backside (left) Frontside (right)

2. Splice factory license plate wiring onto AEV supplied light using the provided black and white pigtails and heat shrink butt connectors. You will be splicing into the passenger side license plate light wiring and leaving the drivers side unused. The white lead on the factory harness will be spliced to the black lead on the supplied license plate light. The black lead on the factory harness will tie to the white lead on the supplied light.



3. Install AEV trailer connector bracket onto top edge of the Center Section using one of the supplied M6x20 button head bolts, washers, and nut (fig. 19).

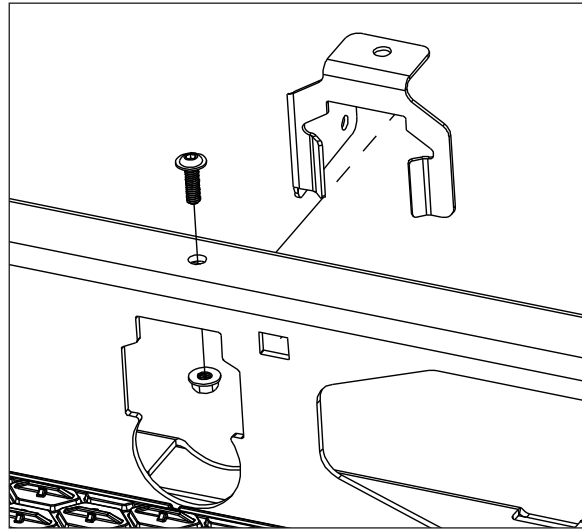

Figure 19

4. Snap factory trailer connector into AEV bracket through front side of bumper.
5. **2019+ Vehicles:** Bundle excess wiring and secure away from mounting points as shown (fig. 20), connect trailer connector to plug.

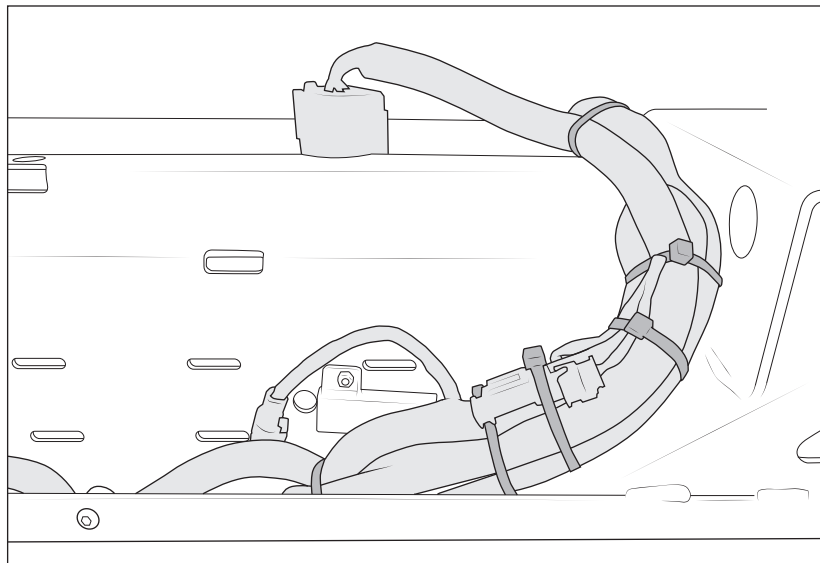

Figure 20



6. If equipped, install passive entry module onto the center section in the shown location and orientation using the supplied M4x12 flanged head bolts and nuts (fig. 21).

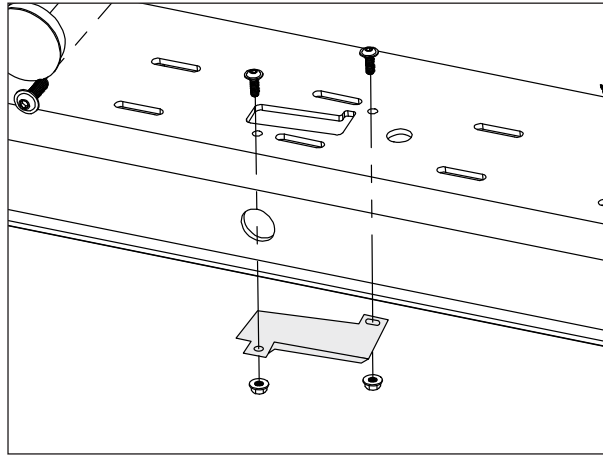

Figure 21

7. If equipped, install Trailer TPMS module onto the center section in the shown location and orientation using two of the supplied M6x20 button head bolts, nylon spacers, and nuts (fig. 22). NOTE: If vehicle is not equipped with module, install the same hardware without the module in place. Finish by snapping 1.5" OD plug into the opening.

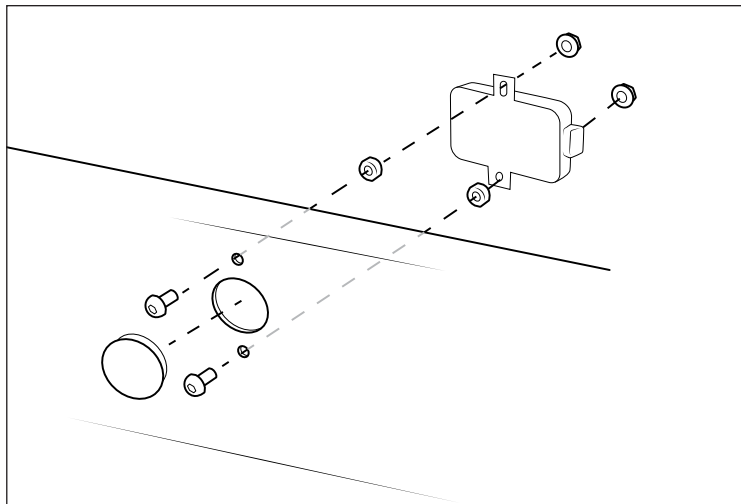

Figure 22



8. If equipped, install two center park sensors onto center section using two of the supplied stainless steel brackets, M6x20 Button head bolts, and washers (fig. 23). It is important that the sensors are installed in the correct orientation. Connectors should be facing inboard when installed. The supplied brackets are designed to allow for bending/adjusting to provide a proper fit. NOTE: 2010–2018 Trucks will need to swap out the rubber isolator rings on all four park sensors with the supplied isolator rings (fig. 24).

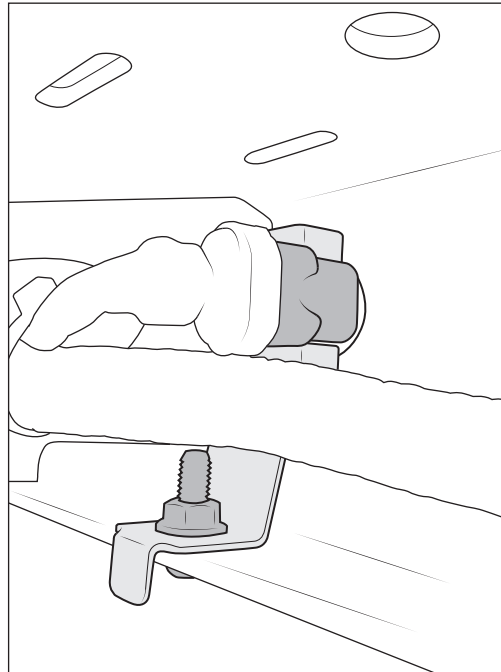

Figure 23

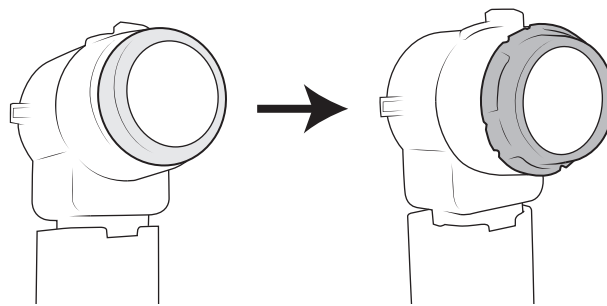
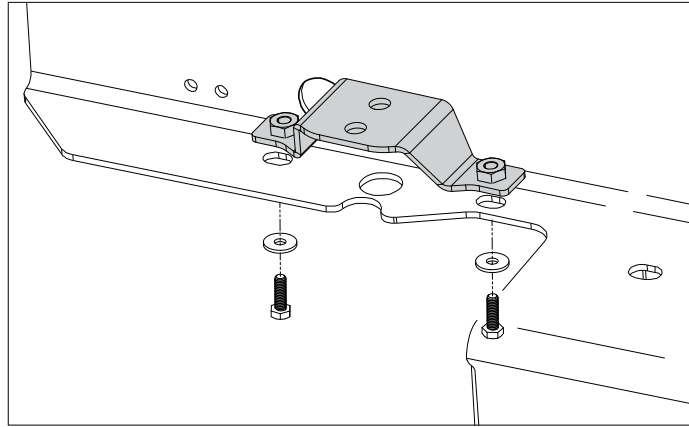

Figure 24

NOTE: It is important that the rubber isolator rings are not pinched or pressed against one side of the bumper opening when installed. The face of the sensor must also be parallel with the face of the bumper center. Failure to do this may lead to poor functionality of the Park Sense system.



9. If you will be installing the optional AEV Auxiliary Light Kit, the brackets can be installed now. If not, skip this step.
  - A. Using two M6x20 hex head bolts and washers, loosely install the Auxiliary Light Brackets onto the bumper at both ends (fig. 25).



*Figure 25*

- B. Install your auxiliary light onto the AEV bracket using hardware supplied by the light manufacturer.
- C. Two mounting locations are provided, use the location that works best for positioning the light closest to the bumper corner tank.
- D. Aiming can be done after the corner tank is installed, but it will be easier with the tank uninstalled. Small adjustments can be made after installation is complete.
- E. Torque the M6 nuts to **7 lb-ft**.



10. Installing AEV Bumper Step Pads:

- A. Install metal retention clips onto seven of the tabs on the back side of each Bumper Step Pad as shown (fig. 26). NOTE: The INBOARD and vehicle FORWARD tabs DO NOT get retention clips. Make sure they are fully seated onto the backside of the step pad.
- B. Snap AEV Step Pads onto the Center Section.
- C. Trim the two tabs without retention clips flush with the bumper surface.

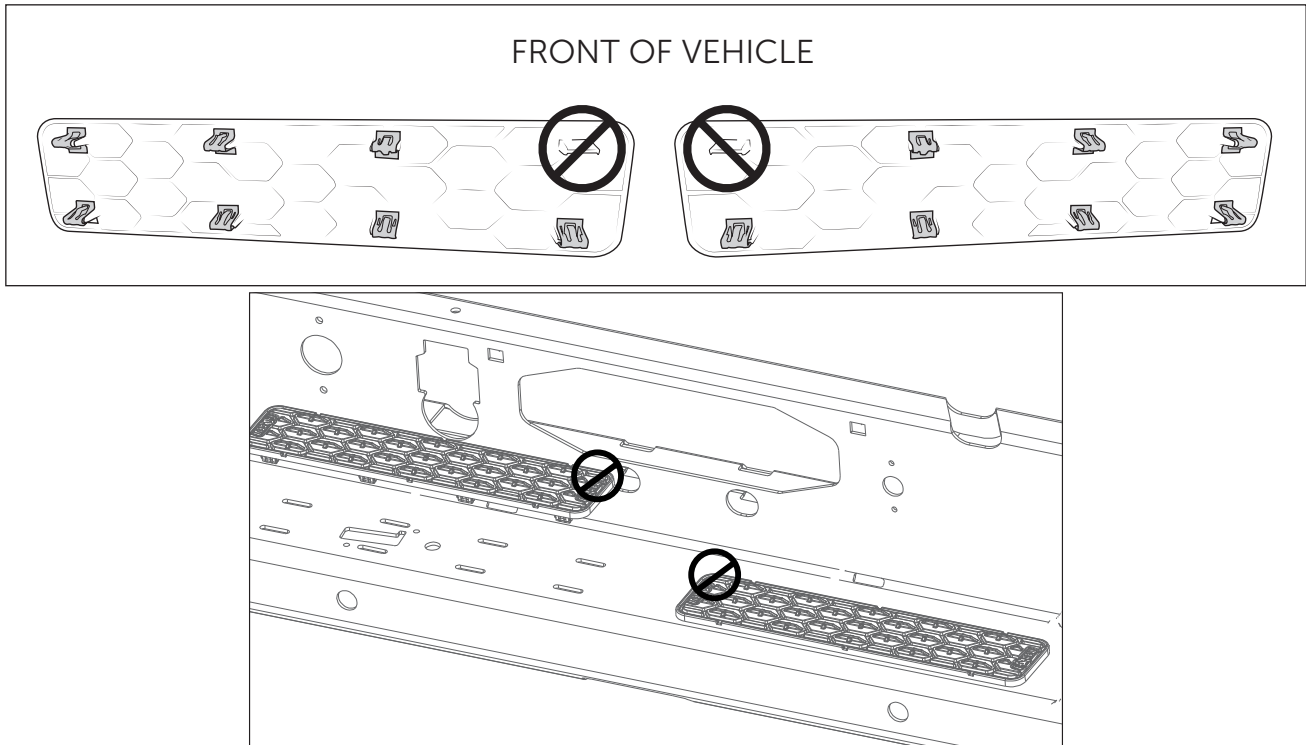

Figure 26

#### IV. INSTALLING CENTER SECTION

1. Lift Bumper Center Section into position using the two center studs as guides.
2. Loosely install the two factory nuts to hold Center Section in place (fig. 27)

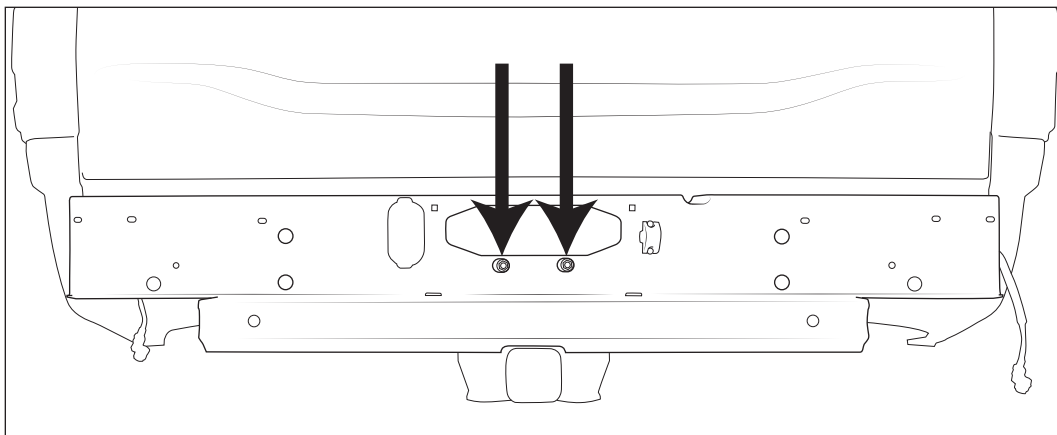
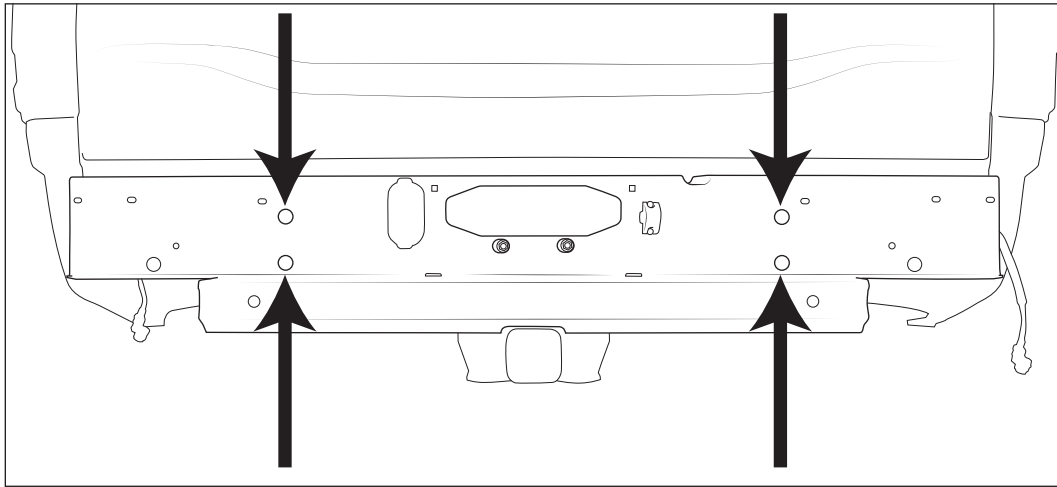

Figure 27





- Align the four holes on the outside face of the center section with frame brackets, loosely install supplied M8x25 bolts and washers (fig. 28). NOTE: It is helpful to loosen the six mounting bolts on the factory hitch assembly to allow for additional adjustment of the center section mounting points.



*Figure 28*

- Align and install the four AEV supplied M12x35 hex head bolts and M12 washers onto the backside of the mounting points of the center section (fig. 29).

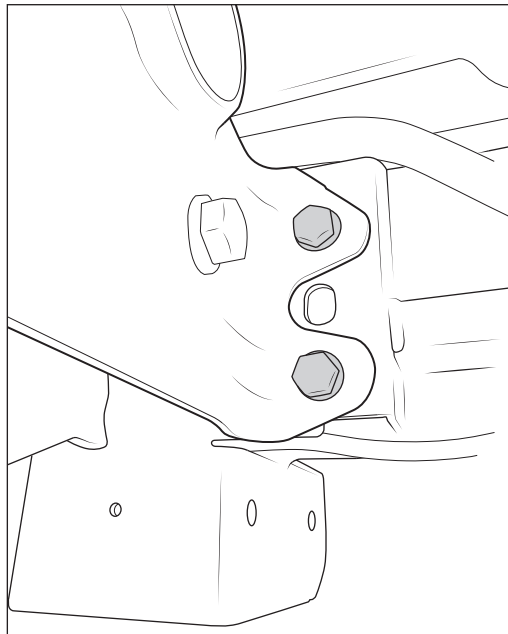

*Figure 29*

- Torque two center mounting nuts to **45 lb-ft.**
- Torque four front side mounting nuts to **16 lb-ft.**
- Torque four rear side mounting bolts to **16 lb-ft.**
- Install the license plate attachment plate using two of the supplied M6 x 1 Button Head Screws and flange nuts. Two snap in plastic nuts are supplied for license plate mounting.



## V. INSTALL FRAME RAIL BRACKETS

1. Remove the spare tire and heat shield.
2. On the passenger side frame rail of 2019 and newer vehicles, there is wiring that will need to be relocated. On 2018 and older vehicles, there is no wiring to relocate.
  - A. Unclip the zip ties from the frame so the harness can be moved above the frame rail. Loosen the bolt on the ground and rotate 90 degrees then tighten back down, the small tab can be bent to sit flush on the frame rail (fig. 30).

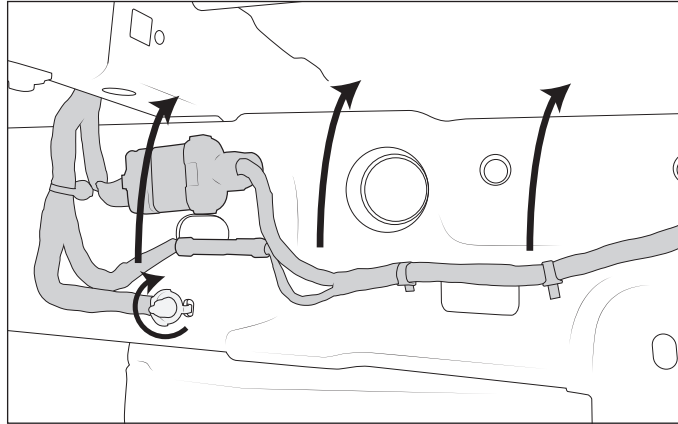

Figure 30

- B. Reinstall the heat shield and install the supplied section of edge guard onto edge of spare tire exhaust heat shield in the area the wires are closest (fig. 31). Failure to do this could allow the harness to be damaged by the edge of the heat shield.

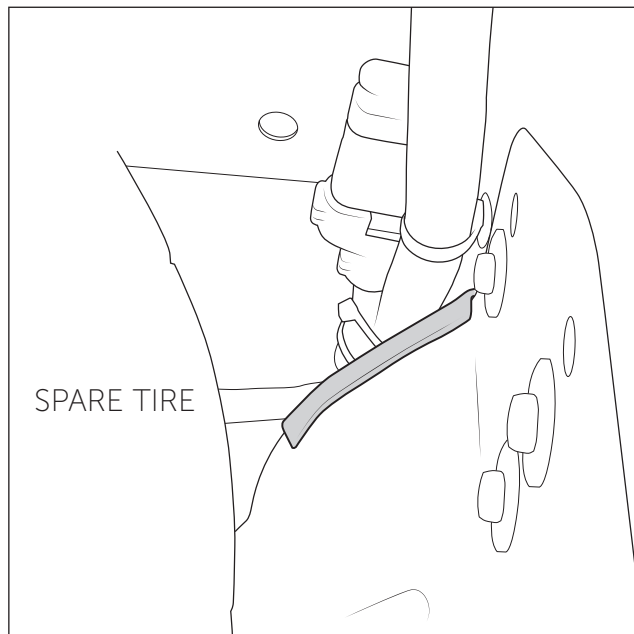

Figure 31



3. Install the two piece frame bracket around the frame rail. Use four supplied M10x25 bolts, washers, and flange nuts to secure. Leave loose at this time (fig. 32: 2019+ shown).

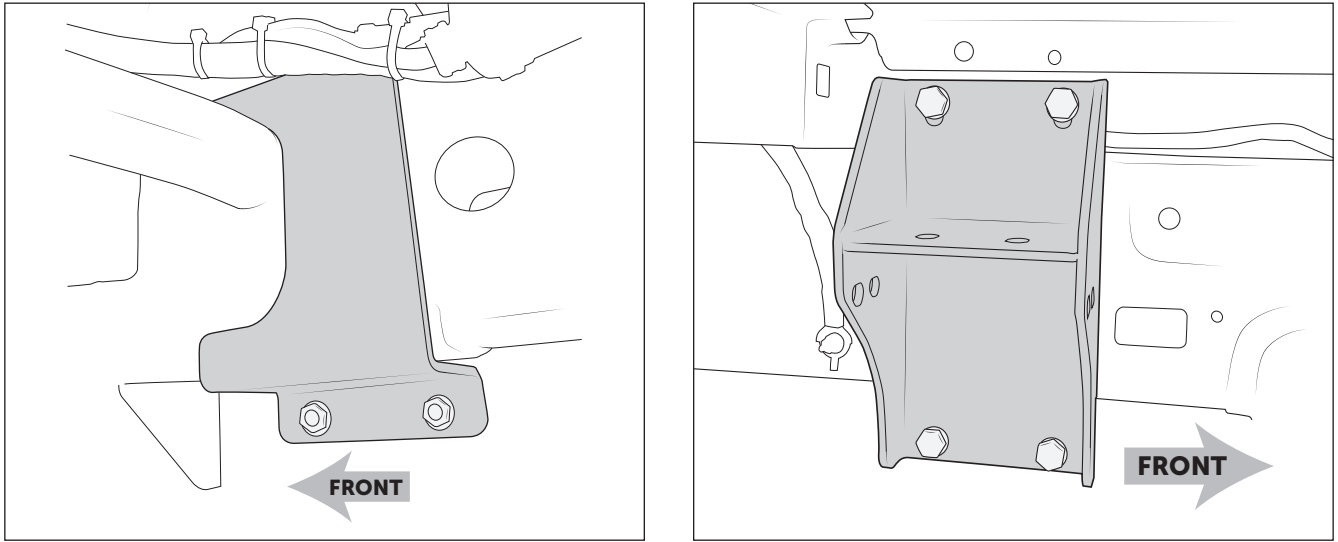

Figure 32 Left: Inboard Bracket Right: Outboard Bracket

4. Install the two piece frame bracket on the driver's side. On 2019 and newer vehicles, there is no wiring on the frame rail to relocate. On 2018 and older vehicles, there is a small harness on the inboard side of the frame rail that is easily moved and reinstall over the frame bracket.

## VI. INSTALLING CORNER TUBES

1. Working one side at a time, remove the three hitch assembly bolts (fig. 33). SAVE hardware.

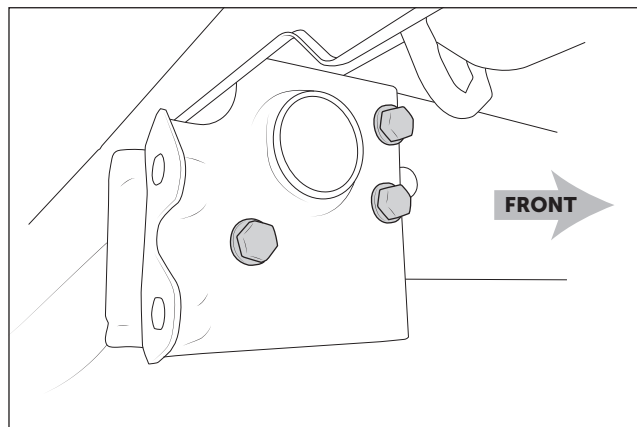
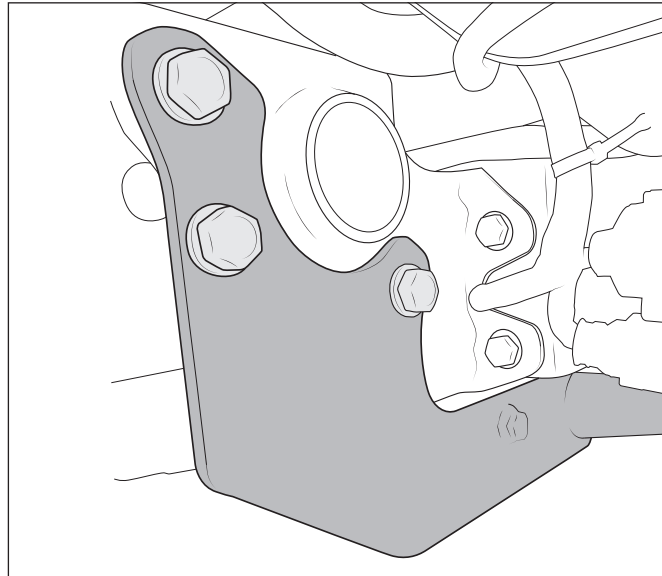

Figure 33



2. Install the supplied 2.5" diameter end caps into the tops of the corner assemblies. Use a mallet if necessary.
3. Lift AEV Corner Assembly into position and loosely reinstall the factory hitch assembly hardware through the mounting plate of the corner assembly (fig. 34).



*Figure 34*

4. Use two supplied M12x50 Hex head bolts to mount the tow hook between the corner assembly and the center section (fig. 35). NOTE: Bolts are installed through openings in the center section. Some of the previously installed wiring may need to be moved to allow tool access.

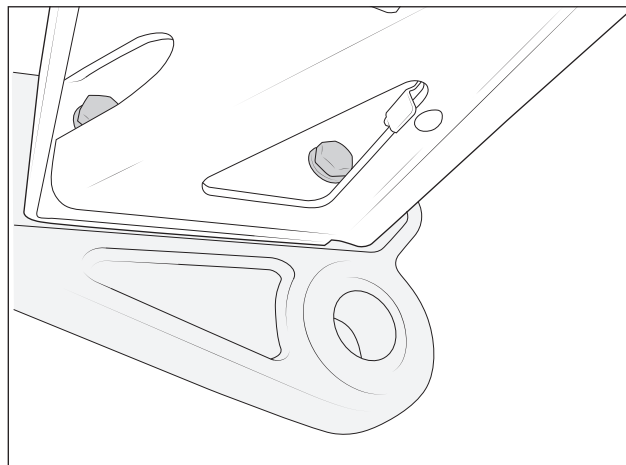

*Figure 35*



- Using three of the supplied M10x25 Hex head bolts, washers, and flange nuts, loosely install the top side of the corner assembly onto the previously installed frame rail bracket (fig. 36). NOTE: 2019+ Coil Spring Suspension option shown.

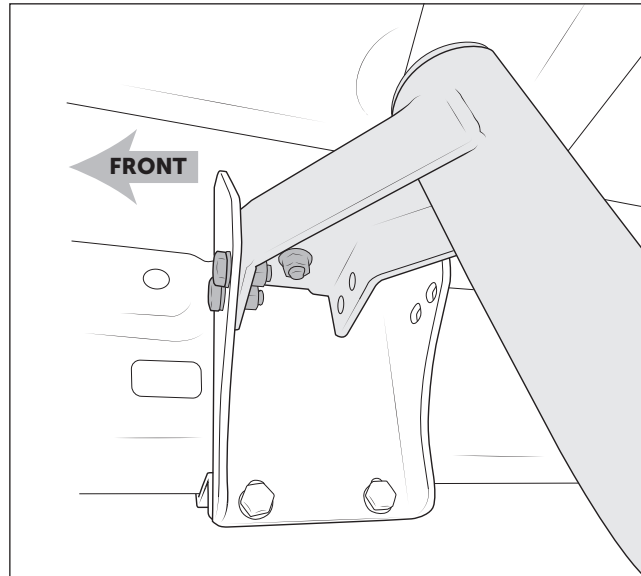

Figure 36: Driver's Side Shown

- Repeat above steps for opposite side corner assembly.
- Torque Hardware in this order:
  - Torque AEV Frame Rail bracket nuts (fig. 32) to **43 lb-ft.**
  - Torque upper corner assembly nuts (fig. 36) to **43 lb-ft.**
  - Torque M12 bolts (fig. 35) to **74 lb-ft.**
  - Torque factory hitch assembly bolts (fig. 34) to **116 lb-ft.**

## VII. INSTALL CORNER TANKS

- If your vehicle is equipped with rear park sensors, you will need to drill out holes in the plastic corner tanks.
  - Using template AEV30397AA, drill the outside sensor holes in the locations shown below (fig 37). Be sure to deburr the holes after drilling. Be sure to check the scale on your template.

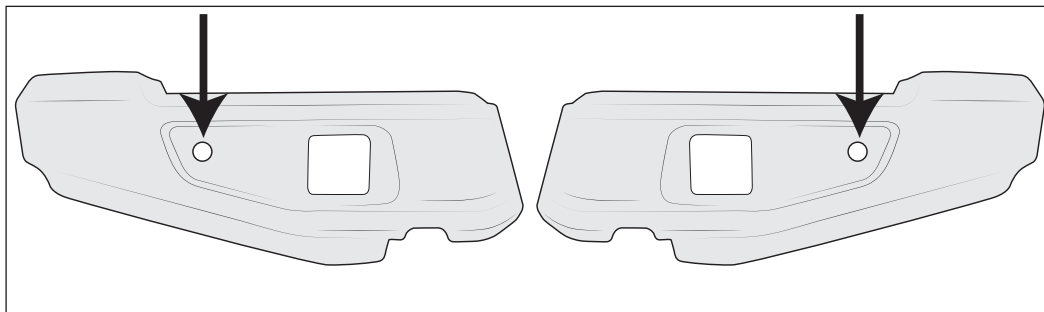
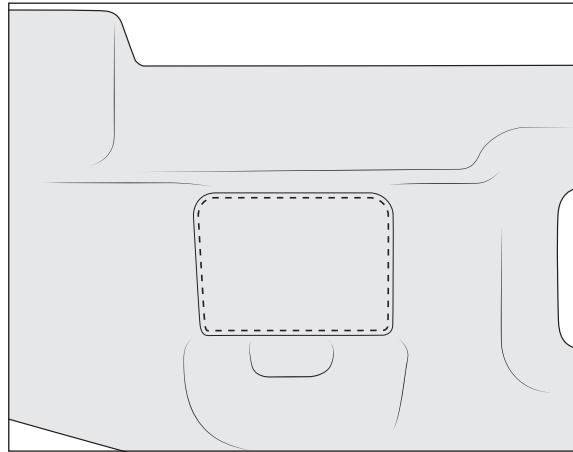

Figure 37



- B. On the inside of the corner tank, cut out the panels shown (fig. 38). NOTE: 2010-18 trucks may require additional trimming to allow for connector clearance.

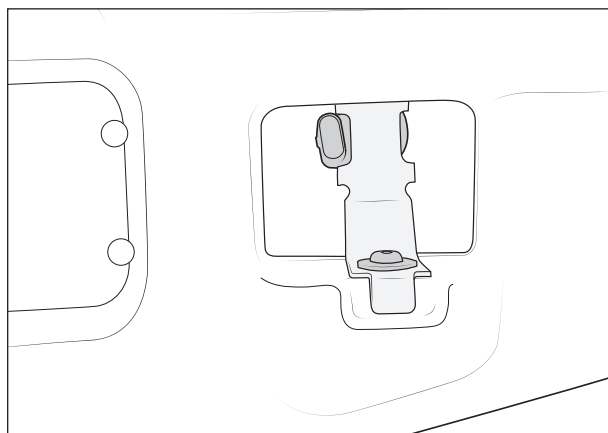

*Figure 38*

- C. AEV recommends drilling a small drain hole in the lowest point of the corner tanks to allow for any trapped water to drain.
- D. Once window has been cut out and the outside hole drilled, install factory park sensor using one of the shorter AEV supplied brackets, a silver M6x16 Hex head bolt, and washer (fig. 39). The sensor connector should be oriented inboard on vehicle.

NOTE: 2010–2018 Trucks will need to swap out the rubber isolator rings on all four park sensors with the supplied isolator rings (fig. 24).

NOTE: It is important that the rubber isolator rings are not pinched or pressed against one side of the bumper opening when installed. The face of the sensor must also be parallel with the face of corner tanks. Failure to do this may lead to poor functionality of the Park Sense system.



*Figure 39*



2. If you are not installing auxiliary lights into your Rear Bumper at this time, install the provided block off plates into the corner tanks using the supplied push in nylon rivets. The supplied red reflective decals can also be installed onto the block-off plates (fig. 40).
  - A. Set block off plate into the recess in the backside of the tank. Using the plate as a template, mark the hole locations for the four push pins.
  - B. Remove the plate from the back of the tank and drill the four marked holes to 1/8". Apply supplied adhesive reflector now if desired. Reinstall plate and install four small plastic push pin fasteners

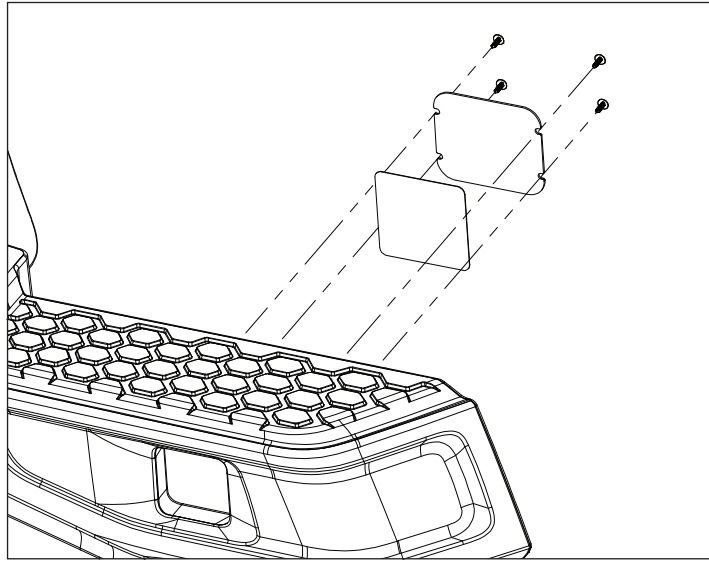

Figure 40

3. Using six of the supplied M8x16 Hex head bolts and washers, install the plastic corner tank onto the center section and corner assemblies. Tighten in the order shown to aid in alignment (fig. 41). NOTE: Installation of the upper inboard bolt will require the removal of the tailgate for tool access.

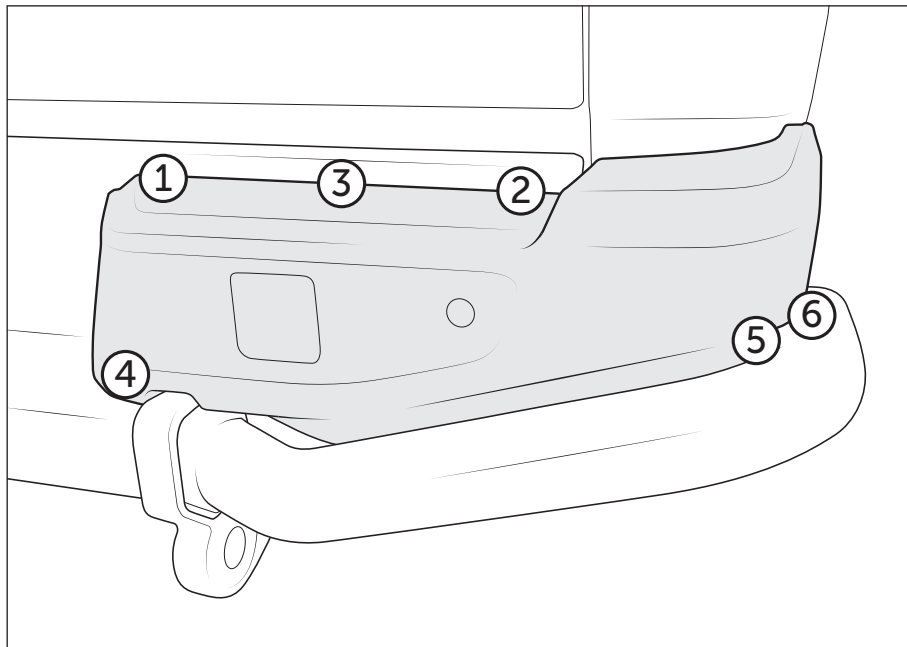

Figure 41



4. If you installed park sensors into your corner tanks, connect them to the previously installed harness.
5. Repeat above steps for opposite side corner tank.
6. Torque all mounting hardware to **16 lb-ft**.

## VIII. DIESEL EXHAUST MODIFICATION 2019+

1. If you are not installing an AEV Diesel Exhaust Tip Kit (PN: 41060309AA), you will need to modify the factory exhaust tip to allow for proper clearance from the AEV Bumper corner. This modification will not provide the same ground clearance as the AEV kit, but will provide proper clearance from the Bumper corner.
  - A. Undo rear most exhaust clamp, located just in front of the rear axle assembly, and slip exhaust apart. Grind down the locating tab shown below to allow rotation of the factory exhaust tip (fig. 42).
  - B. Rotate the factory exhaust tip down to provide roughly 1.5–2 inches of clearance from AEV bumper corner. Tighten down the factory exhaust clamp.

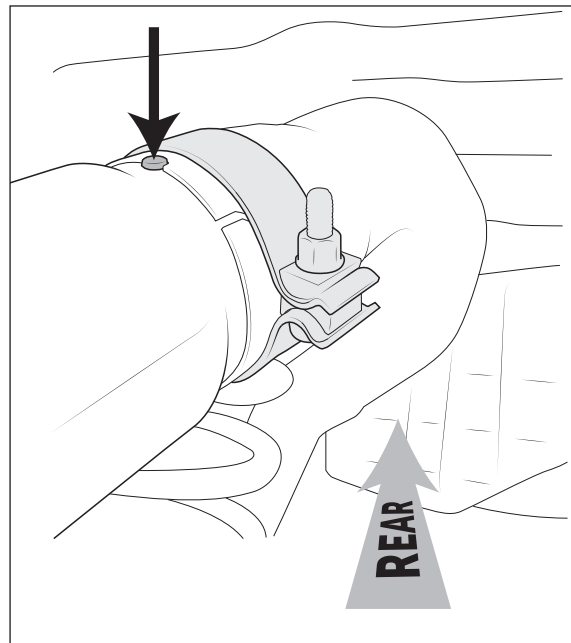

Figure 42

## IX. DIESEL EXHAUST MODIFICATION PRE-2019

1. Pre-2019 trucks do not have a clamp-on end piece. You will need to either cut your exhaust to allow clearance for the AEV bumper corner, or purchase the AEV High Clearance Exhaust Kit (PN: 41060309AA).
2. If you choose to cut your factory exhaust, be sure to provide roughly 1.5-2 inches of clearance between the exhaust and the AEV Corner Assembly.