



REAR BUMPER & TIRE CARRIER

2018+ JEEP WRANGLER

PLEASE READ ENTIRELY BEFORE YOU START

To guarantee a quality installation, we recommend reading these instructions thoroughly before beginning any work. These instructions assume a certain amount of mechanical ability and are not written nor intended for someone not familiar with auto repair.

TABLE OF CONTENTS

- I. Disassembly
- II. Rear Bumper Installation
- III. Installing Park Assist Sensors
- IV. Tire Carrier Installation
- V. Installing Corner Tanks
- VI. Center Section Installation
- VII. Final Tire Carrier Installation
- VIII. Mount Tire and Brake Light

REQUIRED TOOLS

- Common Hand Tools
- Metric Wrenches or Sockets
- Level and/or Measuring Tape
- Drill Motor
- 13/32" Drill Bit
- Rust Preventative such as Permatex Rust Treatment

AEV30417AC

Last Updated: 05/11/21



REAR BUMPER

2018+ JEEP WRANGLER

NO.	PartNo	DESCRIPTION	Default
1	AJLB0200AA	WELDMENT, JL REAR BUMPER, CORNER RH	1
2	AJLB0201AA	WELDMENT, JL REAR BUMPER, CORNER LH	1
3	AJLB0208AC	WELDMENT, JL REAR BUMPER, CENTER SECTION	1
4	AJLB2004AB	BRACKET, JL REAR BUMPER, PARK SENSOR	4
5	AJLB2008AA	TANK, JL REAR BUMPER, CORNER RH	1
6	AJLB2009AA	TANK, JL REAR BUMPER, CORNER LH	1
7	AJLB2022AA	U-BOLT, JL REAR BUMPER, TUBE ATTACH	2
8	AEV93002AB	M10 X 1.5 FLANGE NUT, NON LOCKING CLASS 10.9 (PS11036-SILVER)	6
9	AEV91148AA	M10 X 1.5 X 16 BUTTON HEAD HEX DRIVE SCREW CLASS 10.9	2
10	60406135AA	BADGE, RR BUMPER TANKS (NO STUDS)	2
11	AEV98006AA	M10 FLAT WASHER - PS5873 BLACK	15
12	91306A682	M10 X 1.5 X 25 BUTTON HEAD HEX DRIVE SCREW CLASS 10.9	11
13	AEV98017AA	9/16" SAE FLAT WASHER (PS5873-SILVER)	4
14	AEV91138AA	M14 X 1.5 X 40 HEX HEAD SCREW GRADE 10.9 (PS11036-SILVER)	2
15	AEV93026AA	M14 X 1.5 HEX NUT NON-LOCKING GRADE 10.9 (PS11036-SILVER)	2
16	AEV91121AA	M6 X 1.0 X 16 BUTTON HEAD FLANGED CAP SCREW	4
17	AEV93027AA	M6 X 1.0 FLANGE NUT FREE SPINNING (PS11036 BLACK)	2
18	ACP80010AA	SUB ASSEMBLY, MOLDED STEP PAD 2.75" X 12.75"	1
19	ACP80120AA	SUBASSEMBLY,BEZEL, REAR BUMPER, AUX LIGHT	1
20	AEV91015AA	M10 X 1.5 X 30 HEX HEAD SCREW CLASS 10.9 PS5873/SILVER	2
21	85985K19	LOCKING PANEL PLUG FOR 11/16" ID (PNL THK .016"-.125")	2
22	AEV92003AA	NUT, LICENSE PLATE (NYLON), #14 SCREW	2
23	AJLB204XAA	SPACER, JL REAR BUMPER, CORNER WELDMENT	6(2 OF EA)
24	CCF_3_14_18	PLUG, ROUND TUBING, 3IN	2

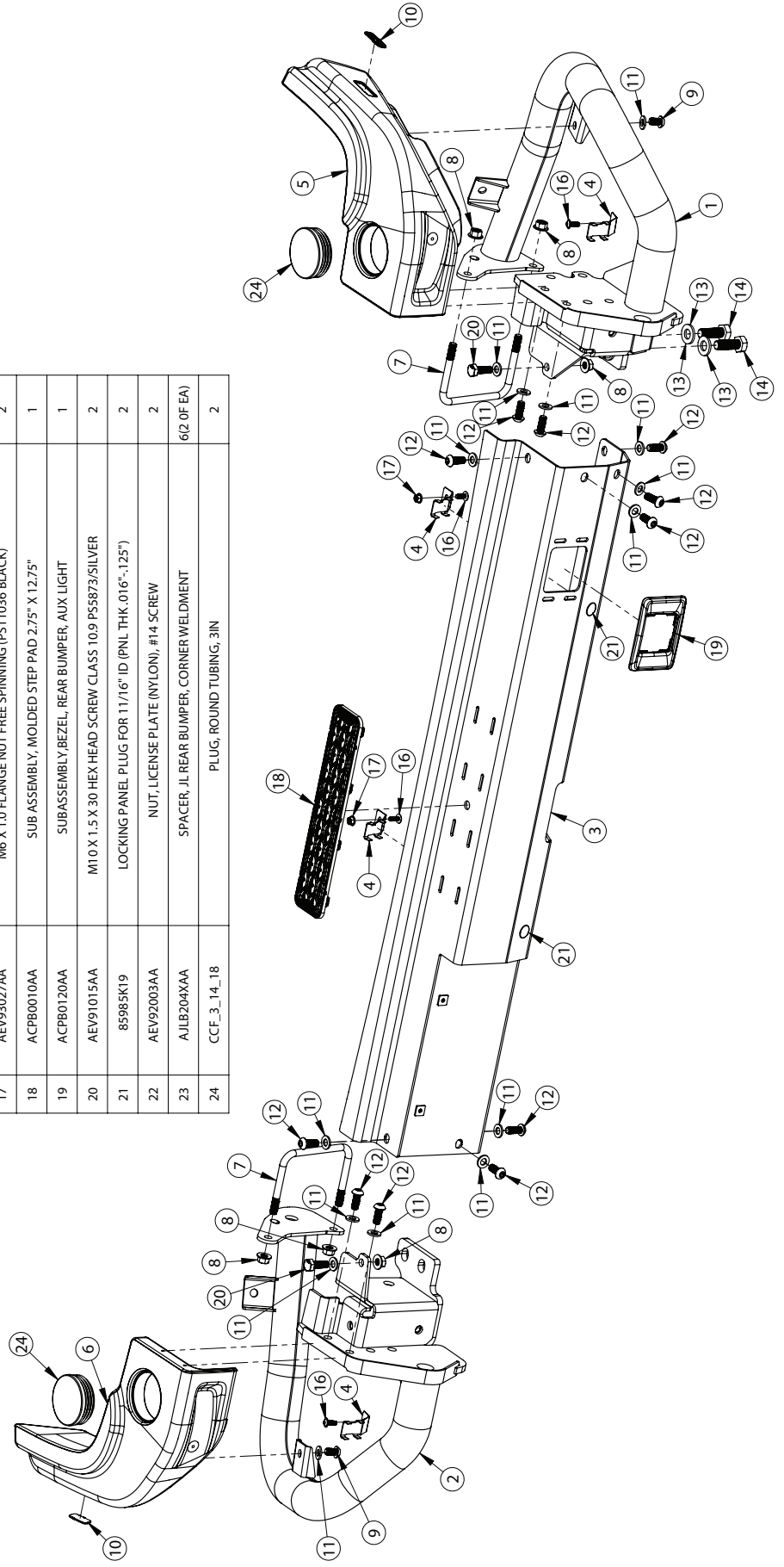



TIRE CARRIER

2018+ JEEP WRANGLER

ITEM NO.	PartNo	DESCRIPTION	QTY.
1	AJKB0210AB	WELDMENT, JK TIRE CARRIER, MAIN	1
2	AJLB0250AA	WELDMENT, JL TIRE CARRIER, SPINDLE MOUNT	1
3	AJKB2118AA	WASHER, JK TIRE CARRIER, BRONZE THRUST	2
4	AJKB2117AA	BUSHING, JK TIRE CARRIER, SPIRAL BRONZE	2
5	AJKB2111AA	PLATE, JK TIRE CARRIER, CAPTURE	1
6	AJLB0022AA	ASSEMBLY, JL TIRE CARRIER, CHMSL	1
7	AJLB0251AA	WELDMENT, JL TIRE CARRIER, TAILGATE ATTACH	1
8	AJKB2119AB	PLATE, JK TIRE CARRIER, SADDLE BLOCK	1
9	27997-SPCLS	LINKAGE, JK TIRE CARRIER	1
10	CCF-2 1/4-10-14	CAP FOR 2 1/4" ROUND TUBING - CAPPLUGS	1
11	AJKB2128AB	WASHER, JK TIRE CARRIER, LOCK/TAB	1
12	AEV91015AA	M10 X 1.5 X 30 HEX HEAD SCREW CLASS 10.9 P55873/SILVER	4
13	AEV98001AB	M10 FLAT WASHER - P55873S SILVER	4
14	AEV98008AC	1/2" SAE FLAT WASHER, P55873 SILVER	15
15	NTH900063	1/2"-20 X 1" HCS, GRADE 8, P5110365	1
16	NTH97001	ZERC FITTING 1/4"- 28 X 90DEG	1
17	AEV91160AA	1/2"-20 X 4" HCS, GRADE 8, P5110365	1
18	AEV91158AA	1/2"-20 X 5" HCS, GRADE 8, P5110365	1
19	AEV98018AA	3/8" SAE FLAT WASHER, P55873 SILVER	2
20	AEV91159AA	3/8"-16 X 1 1/4" HCS, GRADE 8, P5110365	2
21	AEV91078AA	3/8"-16 HEX FLANGE NUT, P5-5873L	2
22	AEV91108AA	M10-1.5 X 20 HCS, P5110365	1
23	AEV91161AA	1/2"-20 X 2" HCS, GRADE 5, P5110365	1
24	AEV91162AA	1/2"-20 X 2 3/4" HCS, GRADE 5, P5110365	1
25	NTH94010AB	1/2"-20 TOP-LOCK NUT, GRADE 5	2

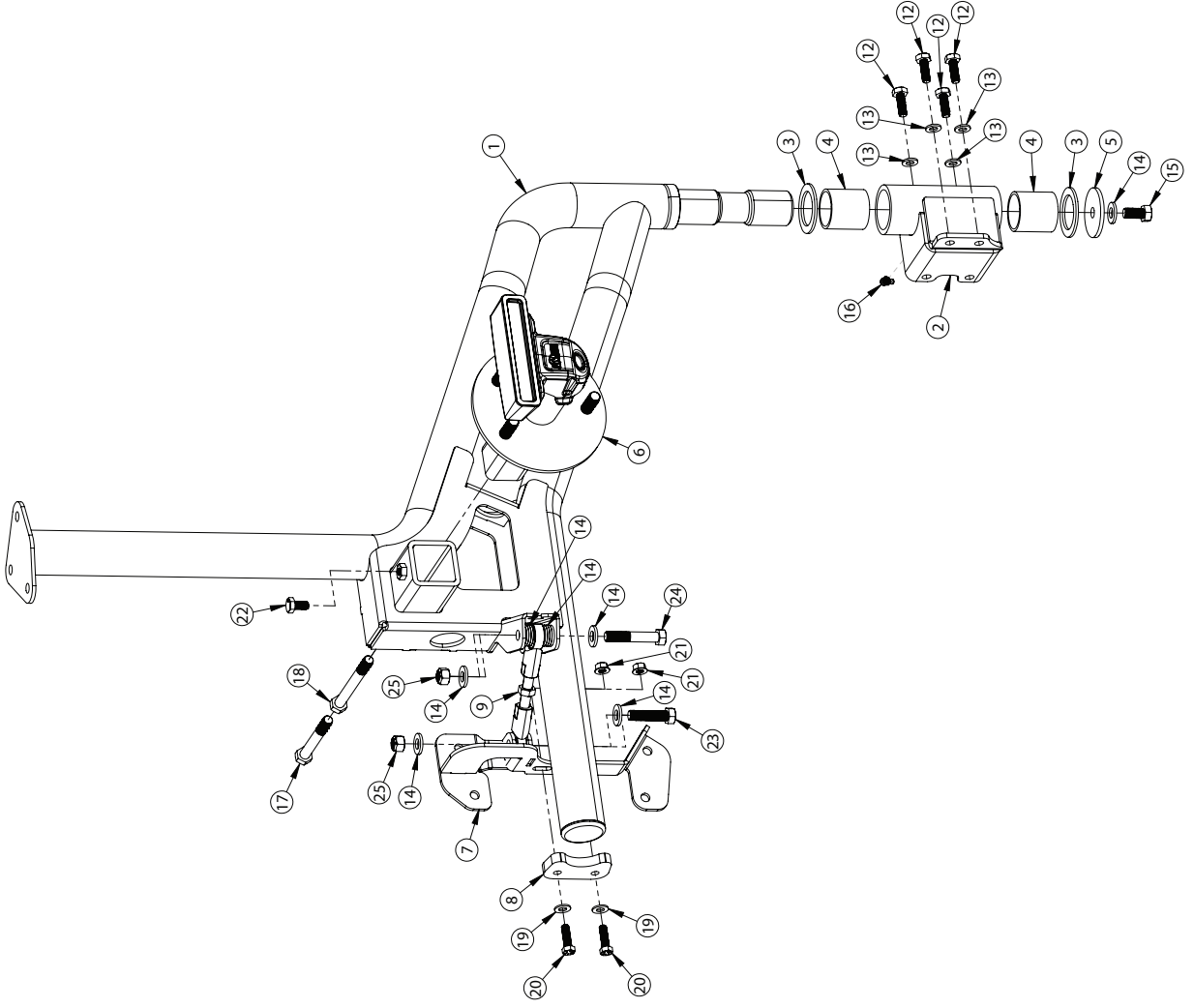

NOT SHOWN: CHMSL/CAMERA HARNESS 30301062AA



BEFORE YOU BEGIN THE INSTALLATION, BE SURE TO CLEAN THE VEHICLE THOROUGHLY.

I. DISASSEMBLY

1. Place the vehicle on level ground. If necessary, use a jack or jack stands to get the frame level for easy measuring during installation.
2. Remove factory rear bumper.
 - A. Remove the camera housing cover using the factory tool kit, then remove the spare tire.
 - B. Unclip the bumper wiring harness. This is located near the frame rail on the left hand side of the vehicle behind the rear wheel liner.
 - C. Remove the four bolts attaching the "L" brackets to the frame and bumper. Remove the brackets and SAVE all hardware.
 - D. Remove the factory tow hook. Unbolt the bumper from the frame rail on the opposite side of the vehicle and remove bumper. SAVE hardware and discard tow hook.
 - E. Carefully remove the wire harness, license plate lamp, housing, hardware, and rear park sensors (if equipped) to be reinstalled in the AEV bumper.
3. Remove factory tire carrier. NOTE: if you are installing the AEV Rear Bumper ONLY, you do not have to remove the factory spare tire carrier and can proceed to step I. PLEASE BE AWARE the factory spare tire on the factory mount will NOT clear the AEV bumper. Relocation brackets may raise the tire enough to clear the bumper but due to added stress on the tailgate and hinges AEV does not recommend this. You may choose to run without a spare tire, but removing the mount will also eliminate the backup camera and Center High Mount Stop Light (CHMSL).
 - A. Open the tailgate and remove the inner panel by pulling straight out from the tailgate.
 - B. Unclip both wiring connections from the chassis harness. Using a trim tool or flat head screwdriver, carefully push outward on the grommet that passes through the tailgate. Once the grommet is popped out, push the harness to the outside of the vehicle through the opening.
 - C. Remove the eight bolts attaching the factory tire carrier to the tailgate and remove tire carrier. Reinstall the four right side bolts into the tailgate and SAVE the other four bolts for later.
 - D. Remove the CHMSL housing from the factory tire carrier. Unclip the wiring harness connector and set aside CHMSL and mounting bolts for reuse.
 - E. From the inside of the tire carrier, remove the three bolts retaining the camera housing to the tire carrier body. Pull the assembly out of the tire carrier. Unbolt camera from mount, unclip wiring connector, and set camera aside for reuse.



II. REAR BUMPER INSTALLATION

1. Install Corner Tubes.
 - A. Remove Corner Tanks from Corner Tubes and SAVE hardware (these are loosely installed for shipping in order to prevent damage from unwanted movement).
 - B. Starting on the left side, carefully install Corner Tube using the factory lower M14 tow hook bolts into the factory weld nuts at the bottom of the frame leaving finger tight (fig. 1).
 - C. Install factory M14 bolts into the side weld nuts but leave loose (fig. 1).

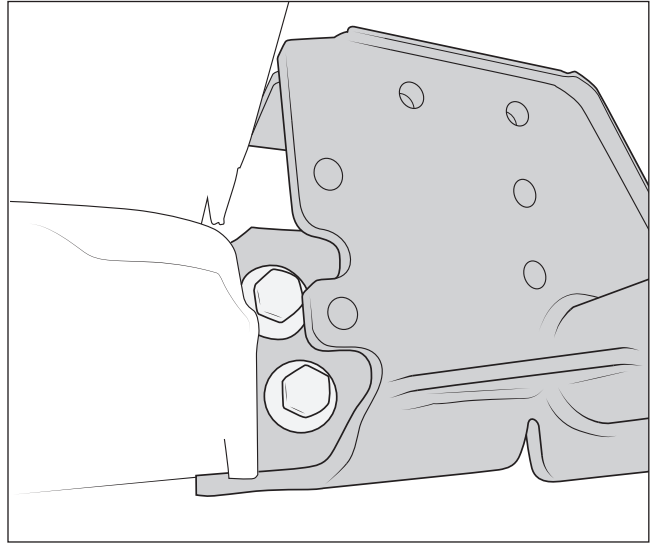
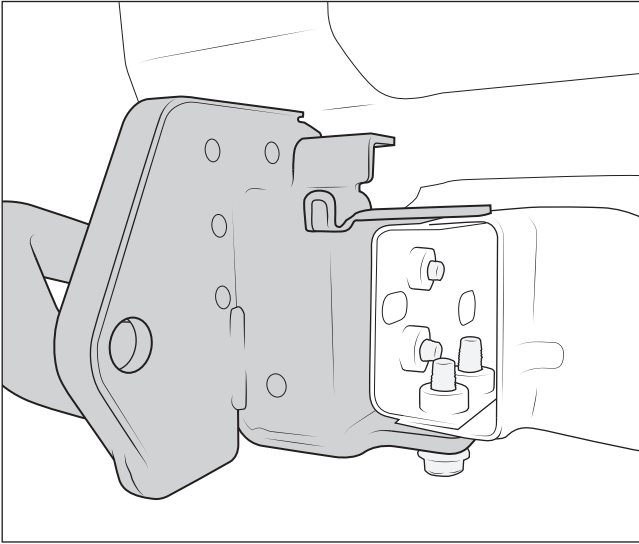

Figure 1

- D. Install the Corner Tube on the right side of the vehicle. Since there was no factory tow hook on this side, use the provided M14 nuts and washers in the bottom of the frame with the factory M14 bolts from the side of the frame. Install the supplied M14 bolts and washers into the side weld nuts on the frame but leave loose (fig. 2).

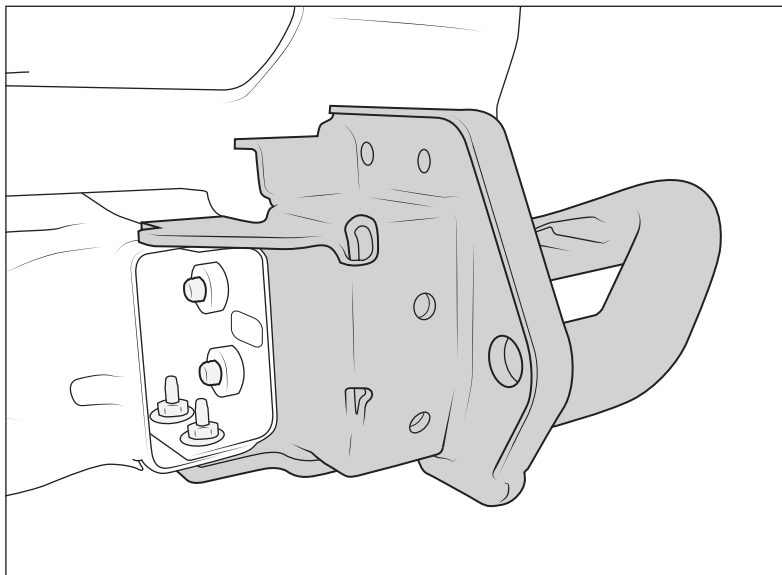

Figure 2



- E. Secure the front end of both Corner Tubes by installing the factory L bracket bolt through the hole in the front bracket, then the provided u-bolts around the frame rail and through the bracket. Hold in place with supplied M10 nuts. Be careful not to pinch any wiring, hoses, or other components with the u-bolts. Tighten all hand tight for now. (fig. 3)

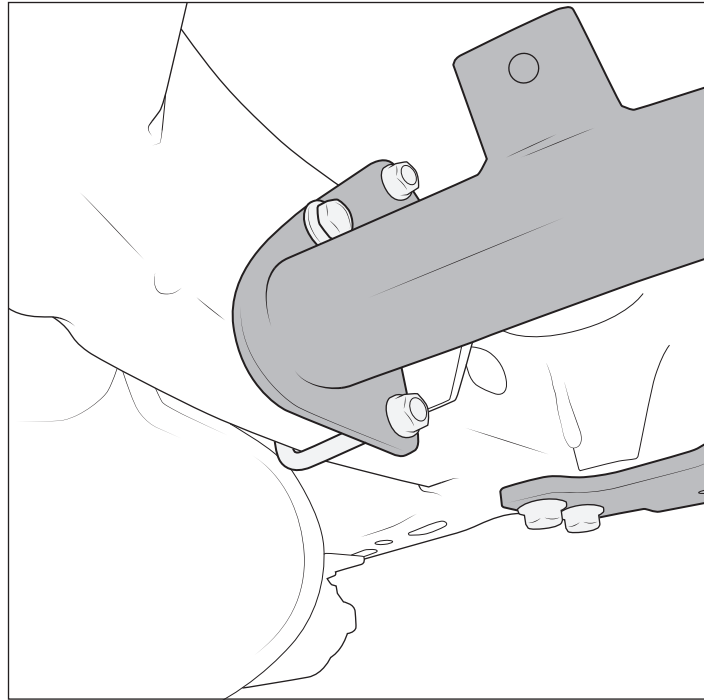

Figure 3

- F. Due to frame variation, some leveling may be needed to get the Corner Tubes to sit properly. Shims are provided in 3 thicknesses to adjust Corner Tubes relative to the frame. If vehicle is sitting perfectly level, a small level can be used on the weldments to ensure they're sitting square to the ground.

Use level to check the angle of the Corner Tube. Typically if the side of the frame isn't perfectly vertical, it will tilt inward slightly toward the top. After adjusting the corner until it sits level, check for gaps to the frame next to the upper mounting hole. If a gap is present, use the provided shims to fill the gap above the bolt. If one shim is loose, use the next thickness up. Hold shim in place and snug the outer top mounting bolt (fig. 4).

Repeat process for the other side.

NOTE: If vehicle is not on level ground, corners can be squared to one another by measuring diagonally from the top of one side to the bottom of the other, then vice versa, and adjusting weldment angle until both measurements match.

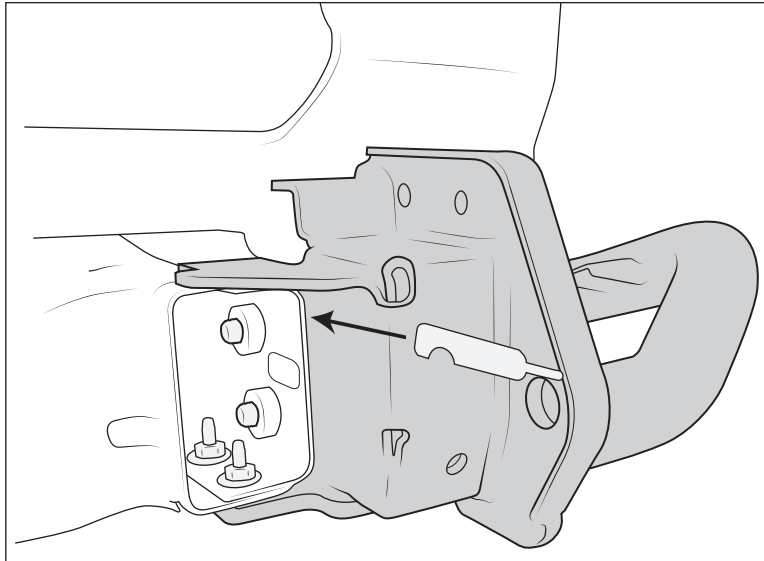

Figure 4

- G. Starting with top outboard bolts, torque all M14 nuts to 130 lb-ft then re-check tow hook level. Adjust shim thickness if necessary. Torque front M10 nuts to 43 lb-ft and u-bolt nuts to 43 lb-ft.
- H. In location of top inboard holes on bumper corners, drill through the frame rail. Deburr the hole and treat bare metal with rust preventative. Install M10x30mm hex head bolt with washer from the top, and a hex nut from the bottom (fig. 5). Torque to 40 lb-ft.

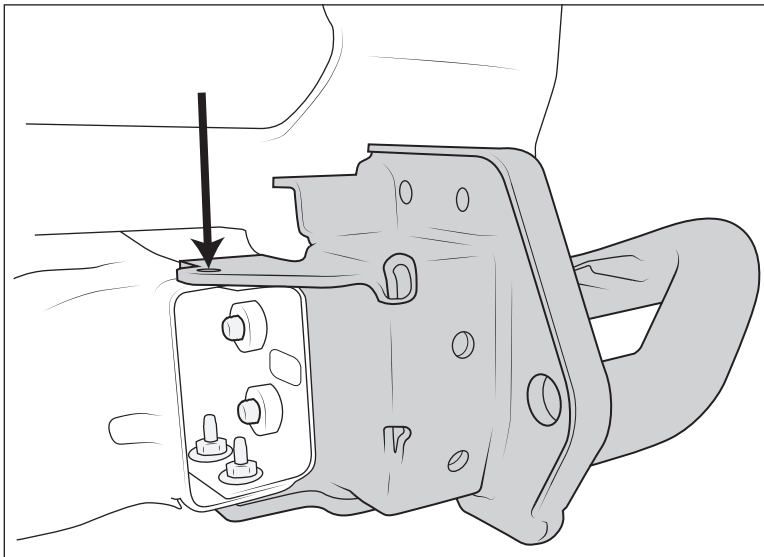

Figure 5



III. INSTALLING PARK ASSIST SENSORS (if equipped)

1. In each corner tank, use molded-in dimple as center point and carefully drill out to 3/4" diameter hole. Be sure to only drill through the outer layer. Suggest drilling in graduated sizes to help ensure it stays centered (fig. 6).

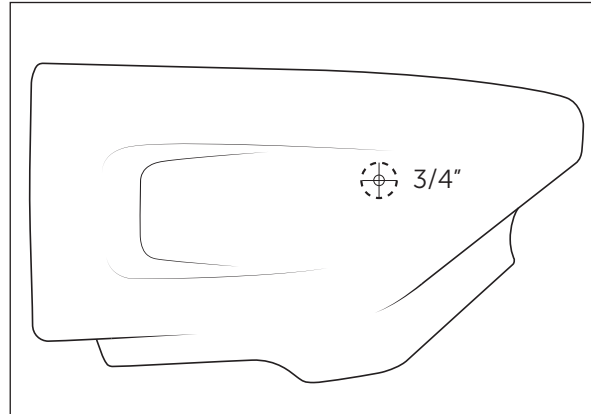

Figure 6

2. In rear of corner tank, locate the molded-in dimple and use it as the center/pilot and drill out using 2" hole saw, being extra cautious not to drill through outside of tank or damage sensor hole (fig. 7).
3. Use utility knife to carefully trim top of hole into square corners (fig. 7). This is for sensor clearance and doesn't need to be exact. If necessary, check sensor fitment to make sure cutout is large enough. Connector should point toward center of vehicle.

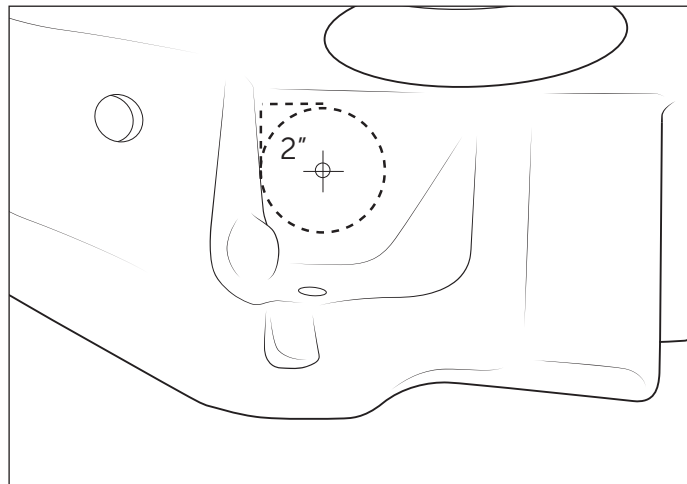

Figure 7



4. Install sensors to corner tanks using provided brackets and M6 bolts and washers. Make sure sensor is centered in hole and fully seated, then torque bolts to 8 lb-ft (fig. 8).

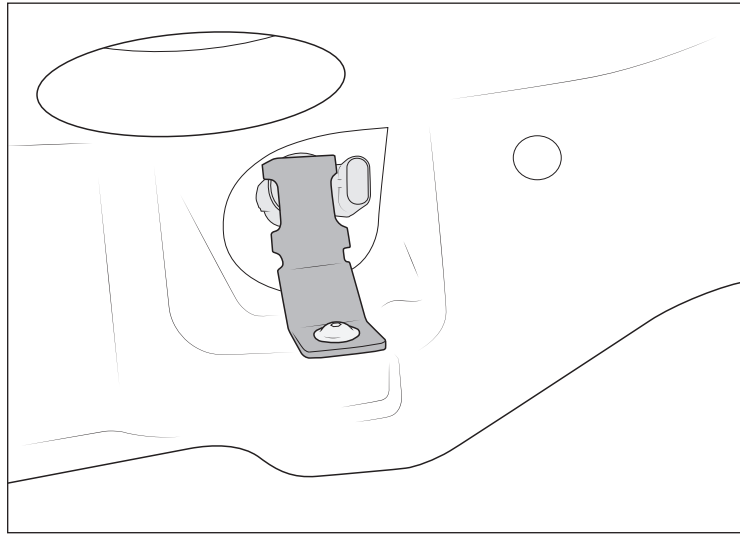

Figure 8

5. Install sensors into center section with the provided brackets. Connectors should point toward center of vehicle. Install supplied bolts and washers from the bottom of the bumper, through the brackets, and install provided nuts from the top. Torque to 8 lb-ft (fig. 9).

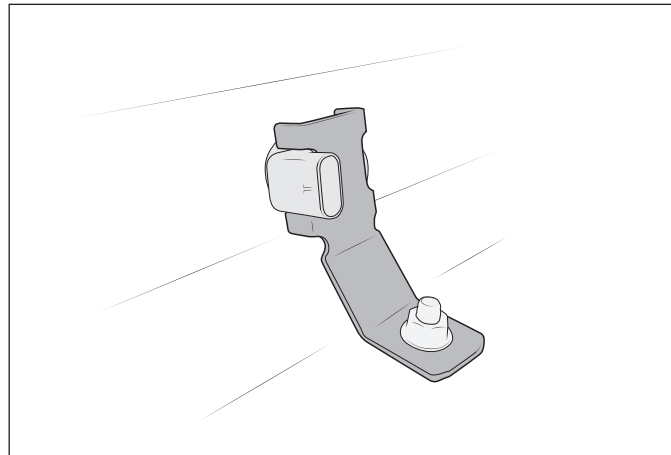

Figure 9



IV. TIRE CARRIER INSTALLATION

If you are not installing the AEV Tire Carrier proceed to Section V.

1. Install the plastic Saddle Block using the 3/8" x 1" bolts with 3/8" washers under the head of each bolt. Install the bolts into the holes on the Saddle block. Use the 3/8" Flange nuts on the inside surface of the AEV Tire Carrier Bracket. Adjust the Saddle Block to its MIDDLE adjustment (fig. 10).

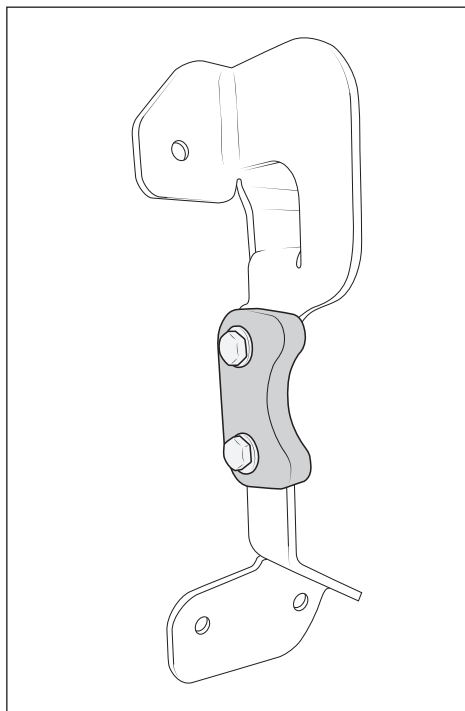

Figure 10

2. Hold tailgate bracket in position using holes as reference points and mark locations where tailgate vent plastic needs to be trimmed. Remove tailgate bracket, carefully trim the plastic using a utility knife (this does not need to be removed from vehicle for this).



3. Reinstall tailgate bracket using factory bolts. Install 2 diagonal bolts first in order to visually verify in the open holes that bracket is centered over threaded holes. Torque bolts to 20 ft-lb max (fig. 11).

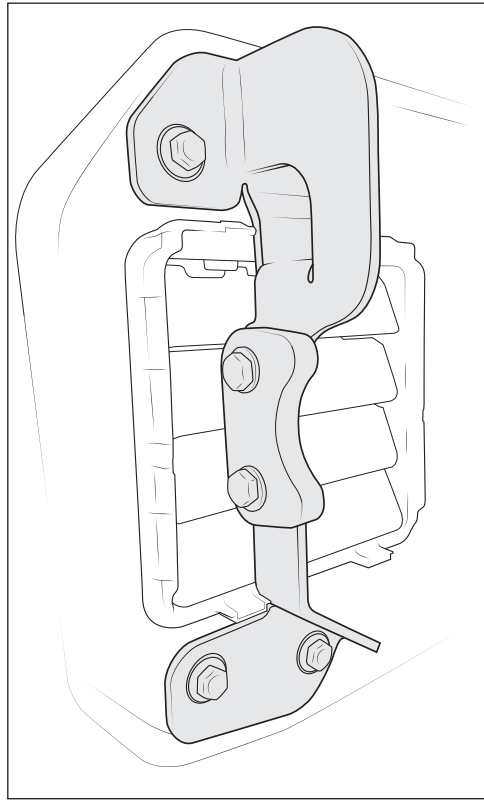

Figure 11

4. Install the Zerk Fitting into the Spindle Housing so that the Zerk is facing DOWN (fig. 12).

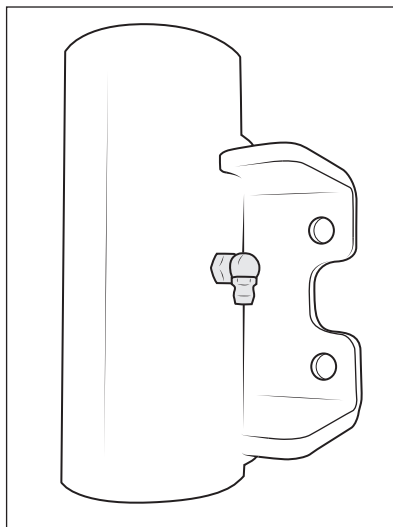

Figure 12



5. Install spindle mount to the right hand corner bracket using four supplied M10x30 hex bolts and washers. Hand snug bolts but do not fully torque yet (fig. 13).

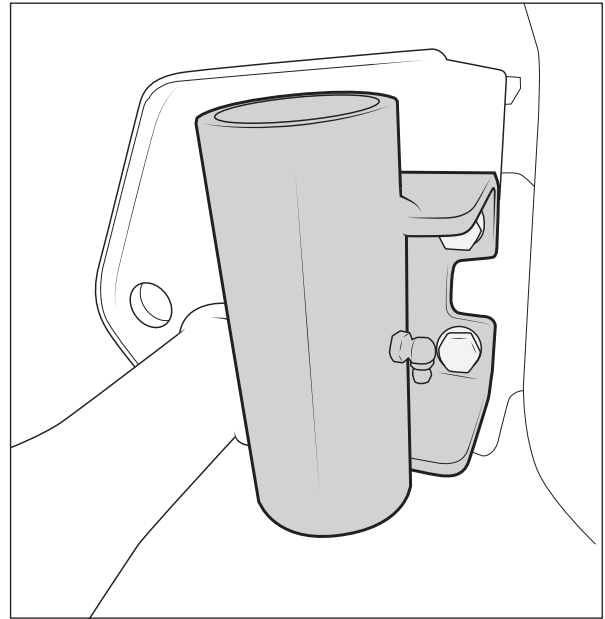
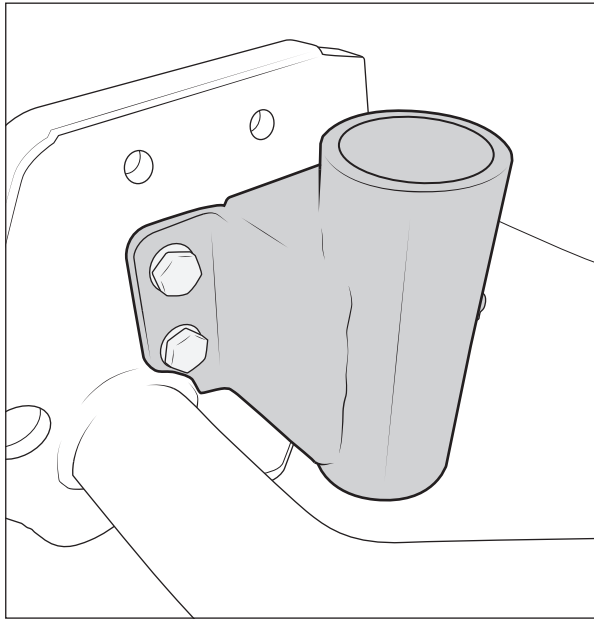

Figure 13

6. Install the Spiral Cut Bronze Bushings into the Spindle Housing at this time. They are designed to have a slight interference fit. Tapping them in with a block of wood or rubber mallet is OK if necessary, BE SURE THEY ARE SEATED FULLY. NEVER USE A METAL HAMMER.
7. The passenger taillight must be temporarily removed to install the tire carrier into the spindle housing. To do so, locate the access panel in the cargo compartment. Pop panel open with trim tool or flathead screwdriver. Locate the white hex head bolt inside the panel. Loosen this bolt and the taillight can be removed from the body. Disconnect wiring harness and set taillight aside to prevent damage. Follow reverse process to reinstall taillight after final installation of tire carrier.



8. Install bronze washer all the way onto the spindle on the Tire Carrier and carefully install the spindle into the spindle housing. Make sure the spindle is fully seated into the housing, then install the other Bronze Washer and steel Retention Disc. Use the fine thread 1/2"x 1" bolt and washer to firmly attach. There is no need to add grease at this time (fig. 14).

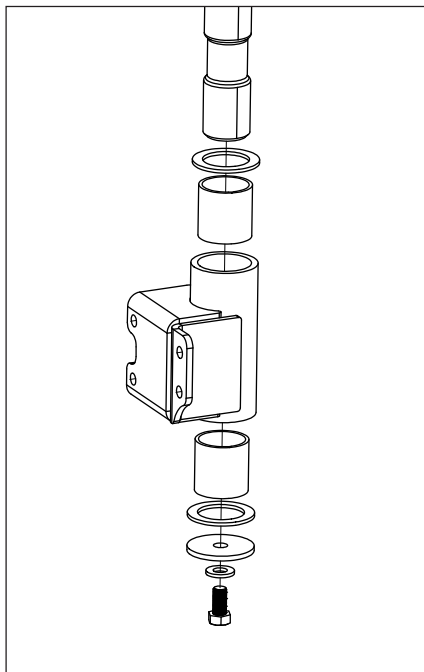

Figure 14

9. With the Spindle Housing on the bumper and the M10 bolts hand tight, close the Tire Carrier and with one hand pressing the Tire Carrier into the Saddle Block, use your other hand to press on the top of the Tire Carrier. This will seat the Spindle Housing properly on the bumper. The goal is to have the Tire Carrier vertical in side view or angled in slightly towards the car if possible. Once in position, tighten all four M10 bolts to 40 ft-lb.
10. Remove the Tire Carrier from the Spindle Housing, but do not remove the Spindle Housing, then proceed to Section V.



V. INSTALL CORNER TANKS

1. Install provided plug into top of left side Corner Tank.
2. If not using the AEV Tire Carrier, install plug into right side Corner Tank.
3. Install Corner Tanks using provided black button head bolts and washers (fig. 15). Recommend anti-seize on these bolt threads, being careful not to get any on visible surfaces of the hardware or bumper. Bottom holes use 16mm long bolts, rear holes use 25mm long. Start all bolts loosely before torquing them down. Visually align corner tanks to body and torque all bolts to 30 ft-lb.

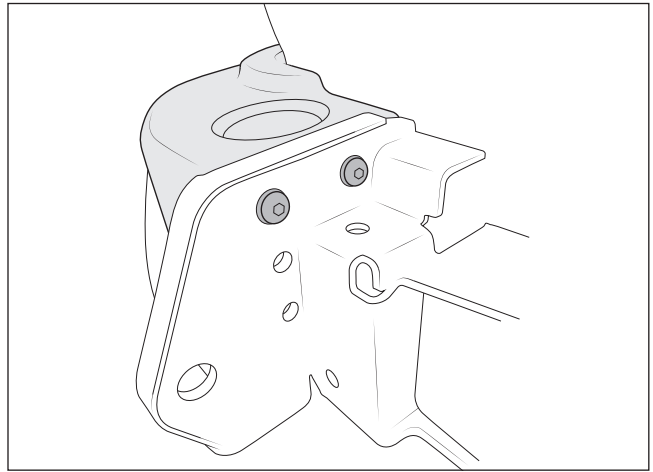
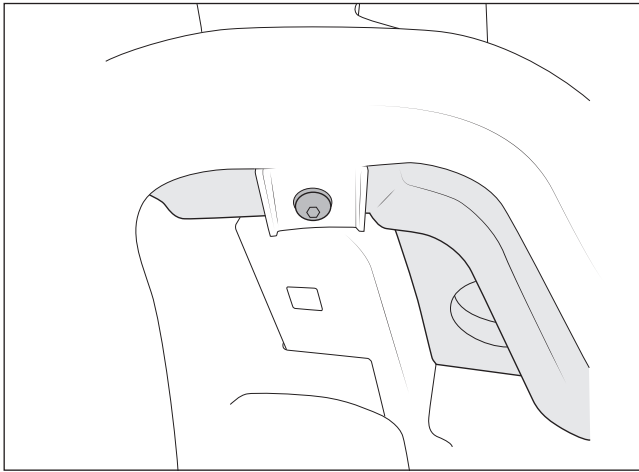

Figure 15 Left: 16mm bolt, Right: 25mm bolts

VI. CENTER SECTION INSTALLATION

1. If Installing the AEV Auxiliary Light Mount, follow the instructions for that product before installing the Center Section.
2. Install center section using provided M10x25 button head bolts and washers. Start all bolts, then torque all to 43 lb-ft (fig. 16).

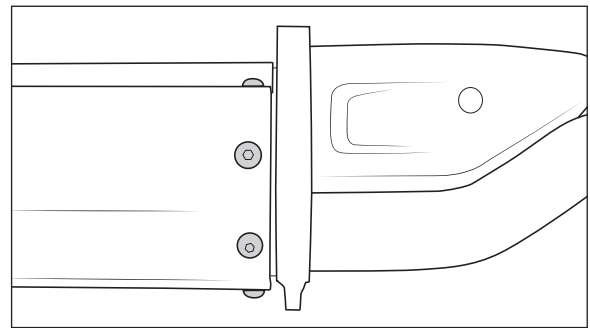
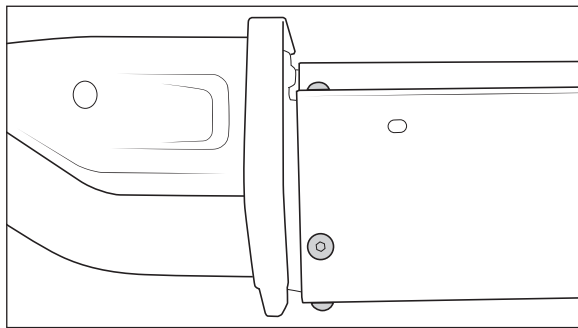

Figure 16



3. Install the metal retainer clips to the tabs on the AEV Step Pad (fig. 17), then clip Step Pad into the Center Section.

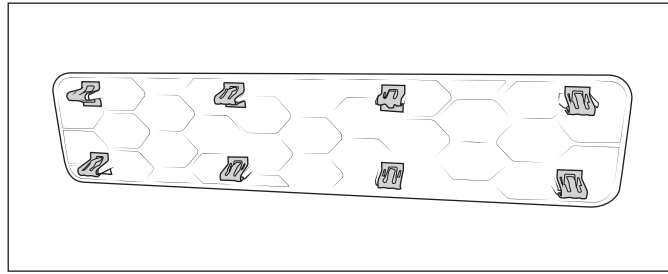

Figure 17

4. If NOT installing a rear auxiliary light, Install four metal retainer clips onto the block-off bezel (fig. 18), then install over the opening in the bumper.

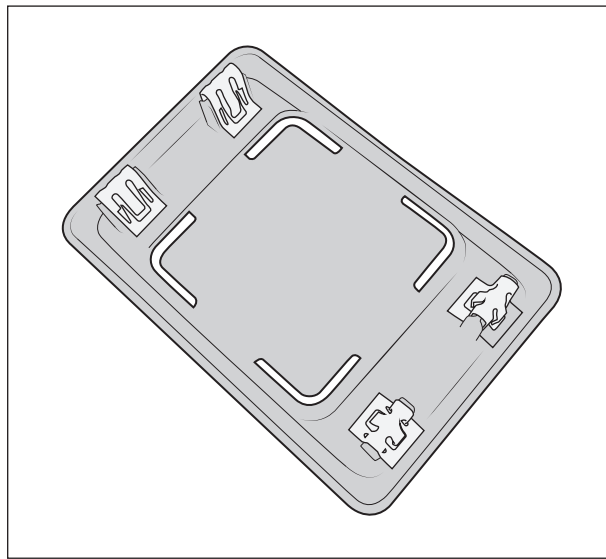

Figure 18

VII. FINAL TIRE CARRIER INSTALLATION

1. Lubricate the spindle, bronze bushings, and washers thoroughly with grease, then reinstall the spindle into the spindle housing, being sure that the bronze bushings are still in place. Make sure the spindle is fully seated into the housing, then install the other Bronze Washer, Steel Retention Disc, and use the fine thread 1/2x1" bolt and washer to firmly attach the Tire Carrier into the Spindle Housing.
2. Tighten the 1/2" Tire Carrier Retention bolt. Test for swing resistance on the Tire Carrier, there should be mild resistance, if there is too much, a thin washer can be placed between the Retention Disc and the Tire Carrier Spindle if necessary.
3. Be sure the Zerk fitting is pointing downward. Fully grease the system at this point. Use any conventional axle bearing grease.
4. Install the Wheel Mount into the Tire Carrier.



- Run wiring harness through the top hole in the square tube of the wheel mount. Route connection for the camera through the end of the tube and third brake light through the slot on the bottom of the tube (fig. 19). Push grommet into the hole in the square tube.

NOTE: Tuck third brake light connector and harness back into the tube to prevent damage when installing wheel and tire assembly onto the tire mount.

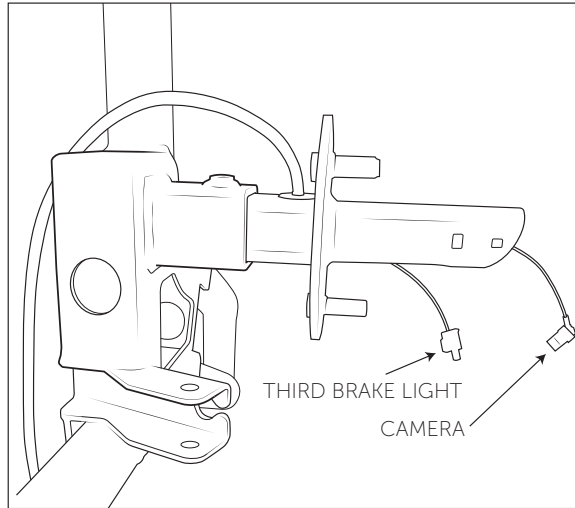

Figure 19

- Install factory camera into clamshell mount (fig. 20) and plug into 90° connector on wiring harness*.

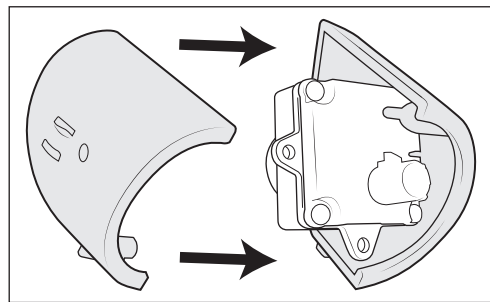

Figure 20

*NOTE: Some vehicles, primarily those with Front Trail Cam, are equipped with a smaller rear camera that will be loose in the clamshell mount. If this is the case, use the provided adhesive backed rubber shim around the camera body (fig. 21). Install the bottom edge of the shim flush with the bottom edge of the camera body. Install the provided O-ring around the camera lens (fig. 22). Then install the camera into the clamshell mount and make sure it is not twisted in the housing. Adjust by hand if needed.

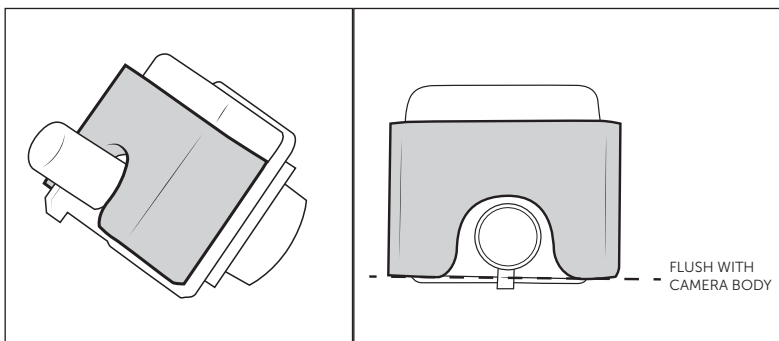

Figure 21

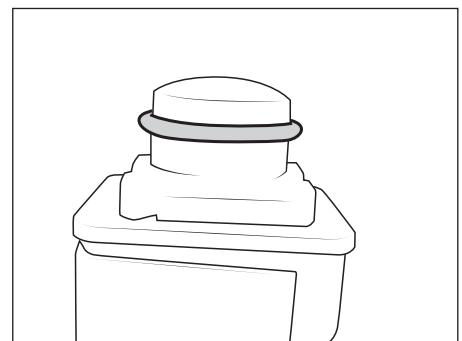

Figure 22



7. Install the camera assembly into the Wheel Mount tube.
8. Install wiring harness through the hole in the tailgate. Wipe silicone or dish soap on the grommet to ease installation, then carefully use trim tool or flathead screwdriver to start grommet into hole. Fully seat it by hand. Route the harness along the tire carrier as shown (fig. 21).

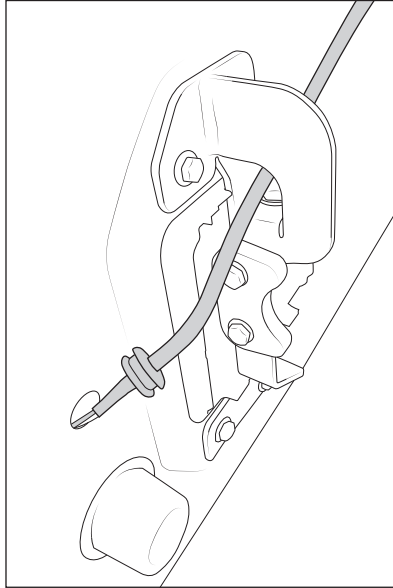

Figure 21

9. Measure the distance from the wheel mounting surface in the wheel to the bulge in the tire sidewall (not wheel backspacing). Subtract 0.25" (6mm) from this measurement to get a default setting.

There are two 1/2" fine thread bolts included. Use the 5" long bolt for backspacing ranging from approximately 5.5" to 7" (factory through AEV JL wheels). Use the 4" long bolt for backspacing ranging from approximately 4" to 5.5" (most other aftermarket wheels). NOTE: While these bolts will accept 99% of wheel and tire combinations, it might be necessary to source a 1/2"-20 bolt of a different length for some applications such as extremely low backspacing.

10. Use Anti-Seize and thread the Tire Mount Bolt with the safety lock washer through the back of the Tire Carrier (fig. 23). The pre-bent tongue will sit in the machined slot as shown. NOTE: It will make locking the safety washer easier later if you slightly bend up the ears prior installing the bolt.

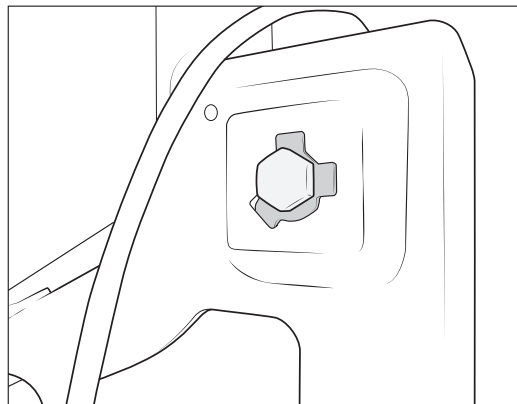

Figure 23



11. Temporarily install the M10 X 20 anti-vibration bolt into the Tire Carrier. Tighten it a bit to prevent the 1/2" bolt from sliding rearward when the tire is initially installed so that it cannot damage the tailgate. Tighten this bolt fully after the tire is on for the first time and after the 1/2" bolt has been adjusted (fig. 24).

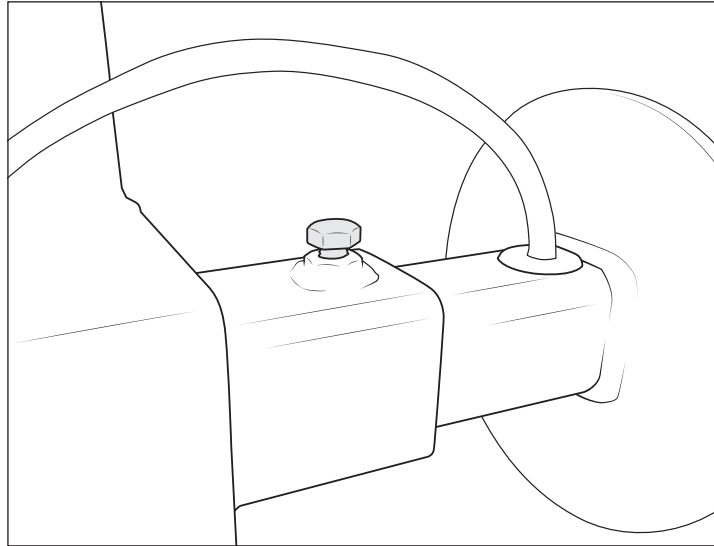

Figure 24

12. Set the Turnbuckle Linkage so that the ends are threaded on equally and about 6.5"-7" from center to center (fig. 25).

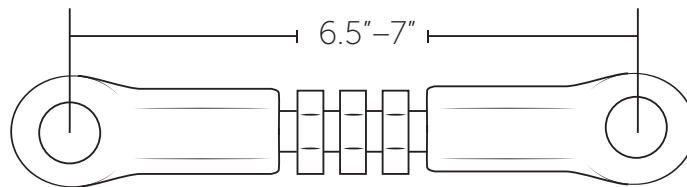

Figure 25

13. Install the Linkage to the Tire Carrier using the 1/2 x 2.5" bolt. This bolt **MUST** pass from the bottom upward with the nut on top. Use washers under the bolt head and nut. Use an even number of washers on both sides of the linkage (fig. 26). Tighten this nut and bolt to achieve a rattle free connection.

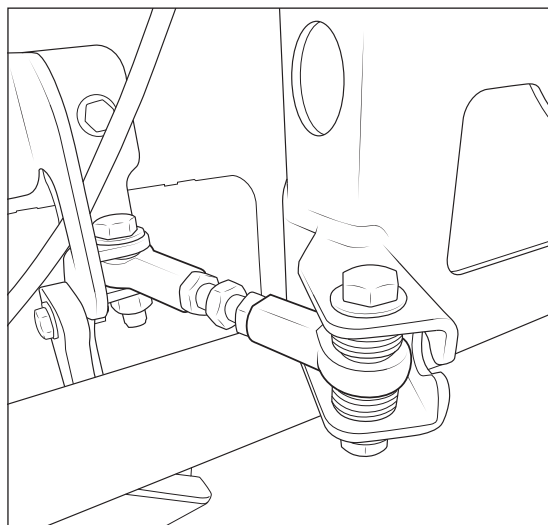

Figure 26



14. Open tailgate about halfway and install the Linkage to the Tailgate Bracket using 1/2 x 1.75" bolt. Use washers under the bolt head and the nut. Tighten this nut and bolt to achieve a rattle free connection.
15. Carefully close the tailgate. If necessary, adjust the saddle block slightly up or down to align it with the horizontal tube. This will be set in final position later once wheel/tire assembly is installed, but it needs to align well enough to close in the meantime (fig. 27).

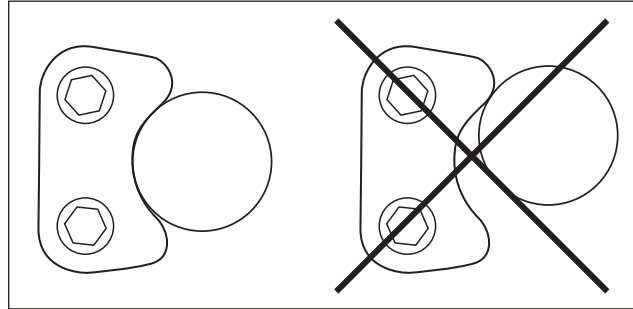

Figure 27

16. Adjust the Turnbuckle Linkage so that the horizontal tube of the tire carrier is fully seated into the Saddle Block. Once it's fully seated, tighten the linkage an additional 1.5 FULL TURNS for a default adjustment. You should now be able to feel tension on the tailgate about 1.5" from its fully closed position.
17. Install Christmas-tree wire tie to hole into hole in tire carrier and retain wire to it, being sure there's enough slack in the harness for the allow full range of motion of tire carrier.

VIII. MOUNT TIRE AND BRAKE LIGHT

1. When doing the final tire install, be sure to tighten the 1/2"-20 bolt so that the tubes of the TIRE CARRIER are all contacting the tire and there is about 1/4" of "squish" in the tire sidewall making sure that the final rotated position of the bolt head aligns the flat side of the bolt parallel with the two tongues of the safety washer.
2. The wheel mount has studs pressed in for a 5 on 5" bolt pattern, if custom axles are used with a different bolt pattern, the studs will need to be pressed out and holes drilled for alternate patterns.
3. Once it is determined that the tire mount has been installed correctly and to the optimal depth, use a hammer and a flat head screwdriver to bend the tongues of the safety washer against the head of the bolt.
4. Install Third Brake Light:
 - A. Trim the alignment pins from the factory third brake light flush with the mounting holes (fig. 28).

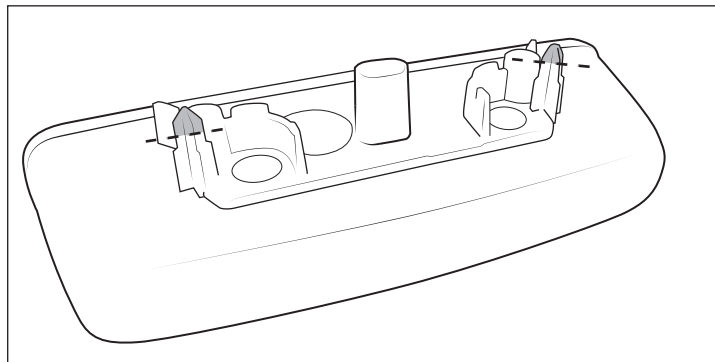

Figure 28



- B. Mount modified third brake light to the AEV bracket using factory hardware (fig. 29).

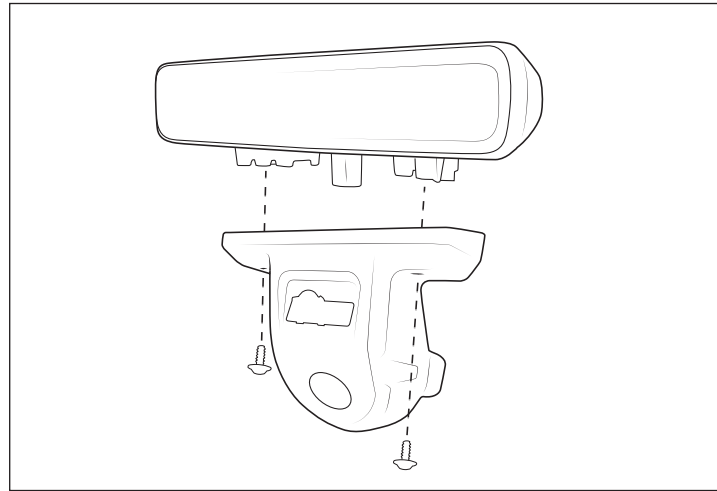

Figure 29

- C. Pull wiring out of the tube and connect to the brake light. Route wiring around the tube, and clip the light assembly into place on the tire carrier tube. Check to make sure the tabs on both sides are fully engaged into the cutouts in the tube for proper retention.