

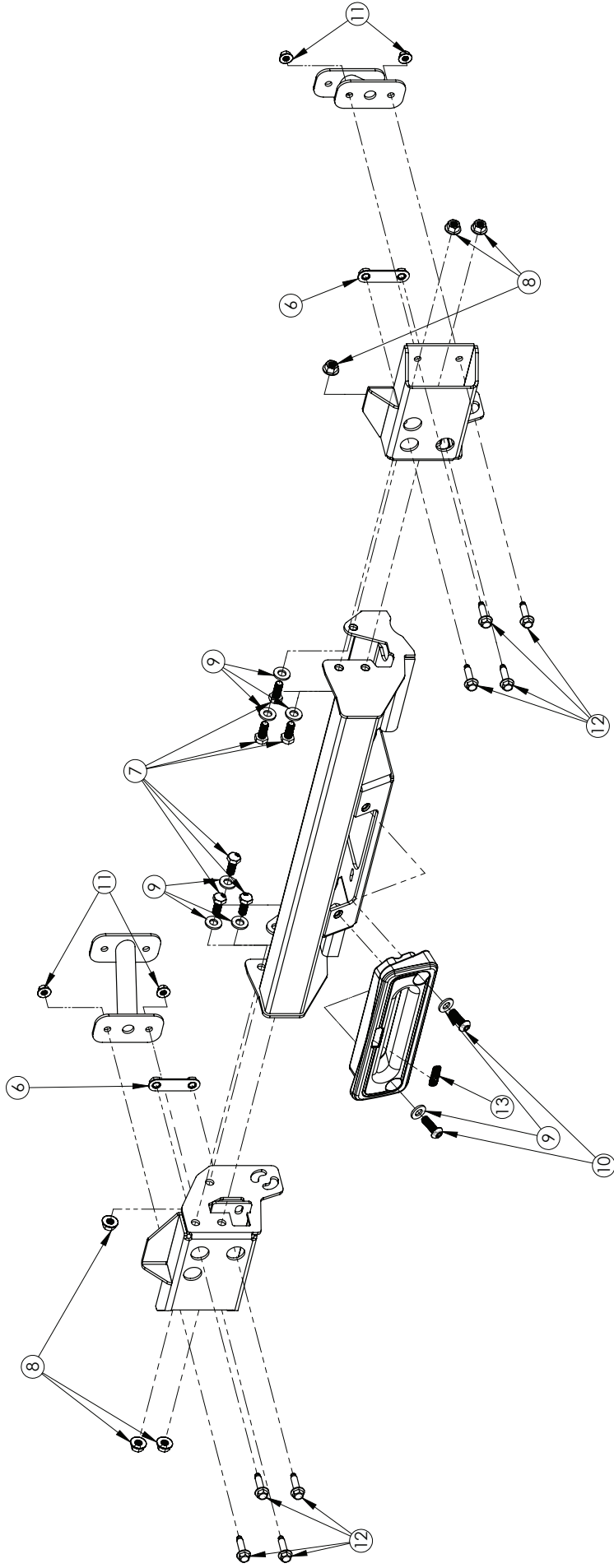

WINCH MOUNT
CHEVY COLORADO ZR2

ITEM NO.	DESCRIPTION	QTY
6	NUT PLATE	2
7	M12 X 1.75 X 30 HEX HEAD CAP SCREW	6
8	M12 X 1.75 NON LOCKING FLAG NUT	6
9	1/2" FENDER WASHER	8
10	12 X 1.75 X 35 BHSCS	2
11	M10 X 1.5 FLANGE NUT	4
12	M10 X 1.5 X 40 HEX FLANGE BOLT	8
13	AEV BADGE	1





PLEASE READ BEFORE YOU START

To guarantee a quality installation, we recommend reading these instructions thoroughly before beginning any work. These instructions assume a certain amount of mechanical ability and are not written nor intended for someone not familiar with auto repair.

INCLUDED PARTS	QTY	REQUIRED TOOLS
Center Section	1	Basic Hand Tools
Frame Mounts	2	Cut-off Wheel
Crush Beams	2	Rivet Gun
Fairlead	1	
Hardware Pack	1	



DISASSEMBLY – SAVE ALL HARDWARE

1. Remove Front Skid Plate.
2. Remove Factory Fascia.
3. Remove Factory Grill Support NOTE: We will cut and reuse this later.
4. Unclip Intake Air temp. NOTE: We will relocate this later.
5. Remove Factory Intrusion beam.
6. Remove factory tow hooks. SAVE tow hooks and hardware.

PREPARE VEHICLE

1. Cut off the lower portion of the Factory Grill Support as shown (fig. 1).

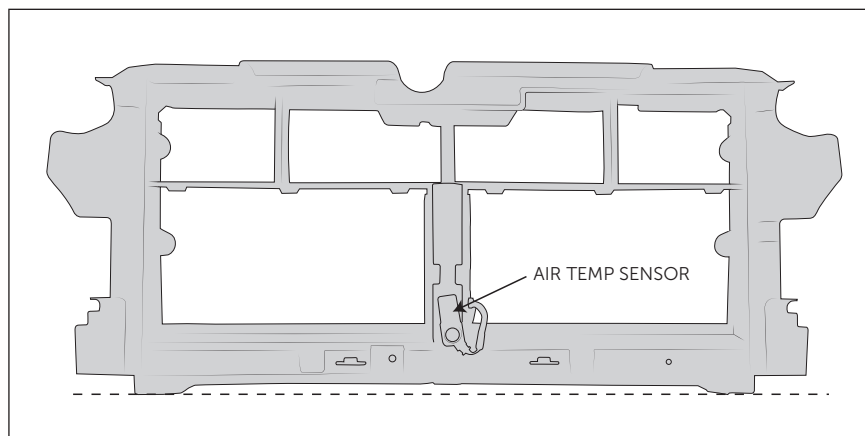

Figure 1

2. Drill a 3/16" hole and rivet in Air Temperature Sensor (fig. 1).
3. Align template (AEV30416AA) to the dimples on the fascia and cut hole for fairlead (fig. 2).

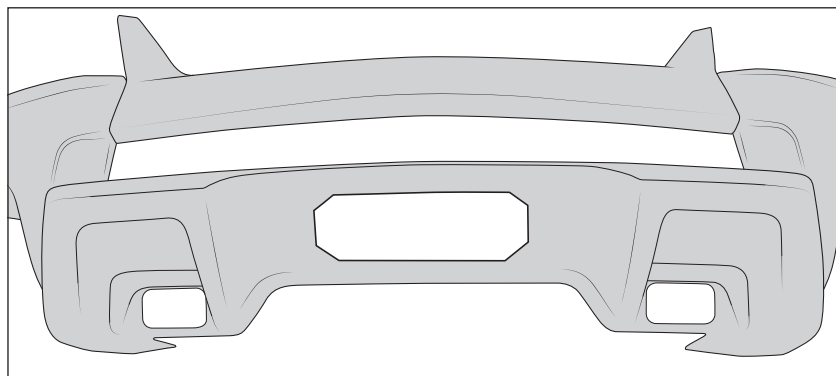

Figure 2



INSTALLATION

1. Install frame mount brackets using two M10 bolts in the factory locations (fig. 3).

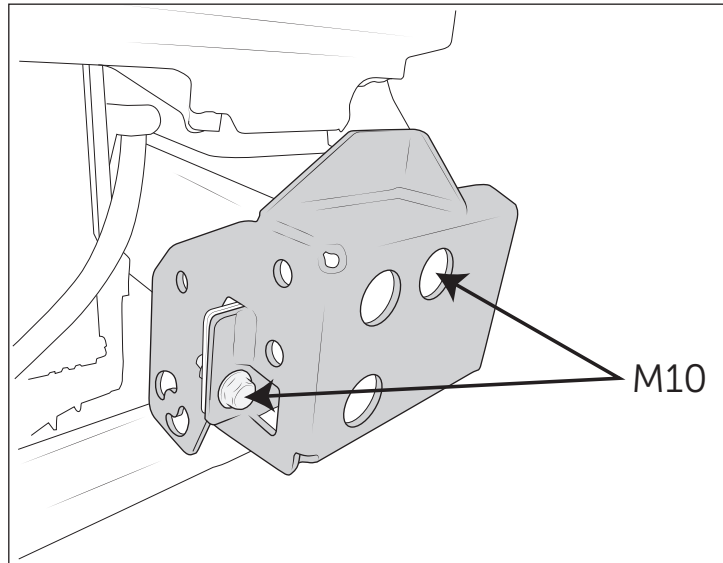

Figure 3: Driver-side Shown

2. Insert flag nut into frame rail and start two M10 bolts (fig. 4).

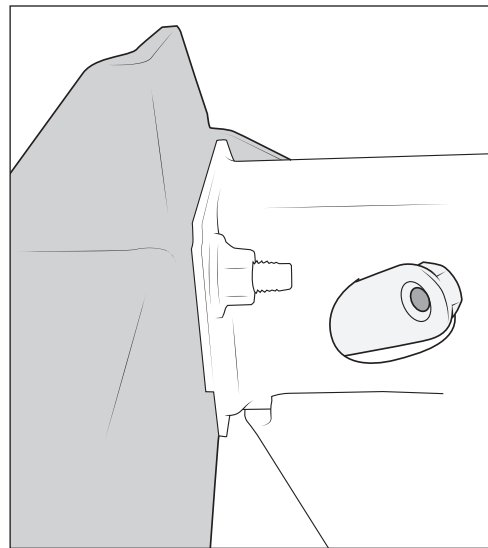

Figure 4

NOTE: Do Not install tow hooks at this point



3. Install center section using three M12 bolts per side (fig. 5).

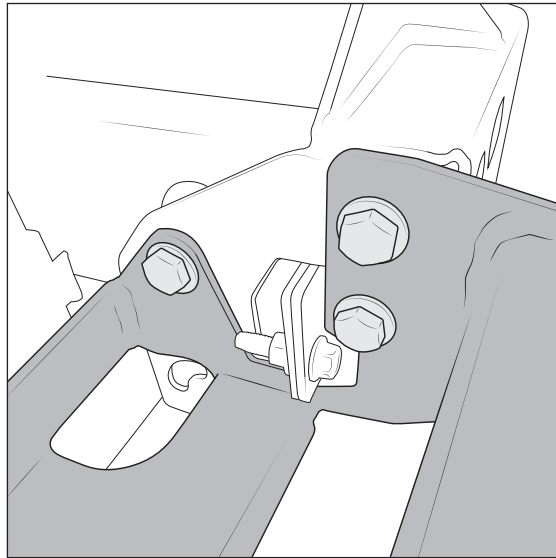

Figure 5: Driver-side shown

4. Reinstall tow hooks using factory hardware (fig. 6).
NOTE: tow hooks sits under bracket.

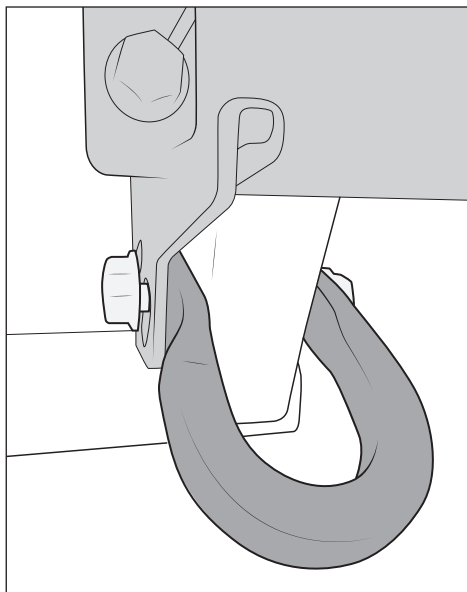

Figure 6

5. Tighten all fasteners. Torque M10 bolts to 43 ft-lbs and M12 bolts to 74 ft-lbs.
Torque Tow Hook nuts to 118 ft-lbs. NOTE: while tightening pull upward on tow hooks.



6. Install winch into Center Section using the hardware provided with the winch. NOTE: Attach ground wire to winch BEFORE fastening winch in place.
7. Install side crush beams using two supplied M10 bolts and nuts (fig. 7). Torque nuts to 43 ft-lbs.

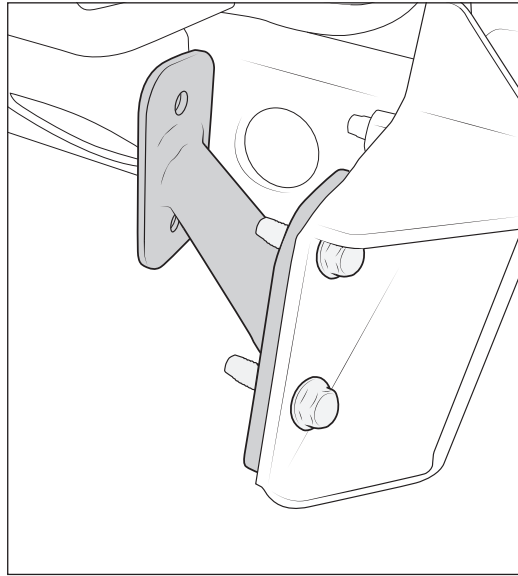

Figure 7: Passenger-side shown

8. Route Wiring. If using AEV Warn Mounting Kit (PN: 18060016) See I Sheet AEV30411AA for that product.
9. Trim the upper, inside corners of the factory foam and around tow hooks (fig. 8)

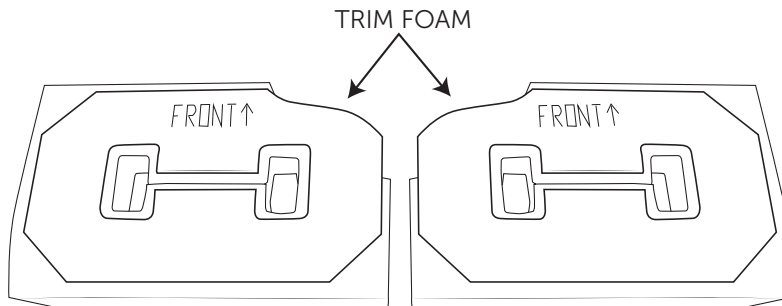

Figure 8

10. Reinstall Factory Grill support.
11. Reinstall fascia.
12. Reinstall Front Skid Plate. NOTE: If using AEV's Front License Plate Mount (PN: 18060015), follow mounting instructions for that product first.



13. Install AEV badge onto Fairlead. Clean surface with supplied alcohol wipe, apply badge with firm pressure for 30 seconds.
14. Install fairlead using two supplied M12 bolts (fig. 8). Torque nuts to 74 ft-lbs.

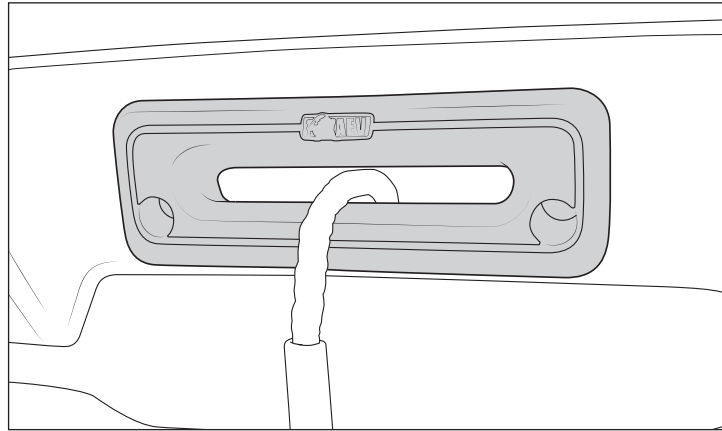

Figure 8

15. Install winch hook. AEV recommends using our Winch Hook Isolator (PN: 80808014AA).