

0 1/2" 1"

AEV Pre-2021 Colorado, 35" Front Fender Trim Template LH

AEV30368AC
1" Square for Scale

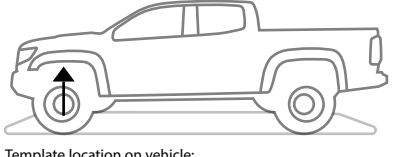

Template location on vehicle:

- KEY:**
- - - Primary make/model paper cutline & template alignment line
 - ==== Sheetmetal trim line
 - ==== Fold line/ inside template alignment line
 - ==== Background data line
 - ✂ Cut paper template
 - ⊕ Drill hole (w/ centerpunch alignment)
 - Alignment hole
 - ↷ Instruction locator

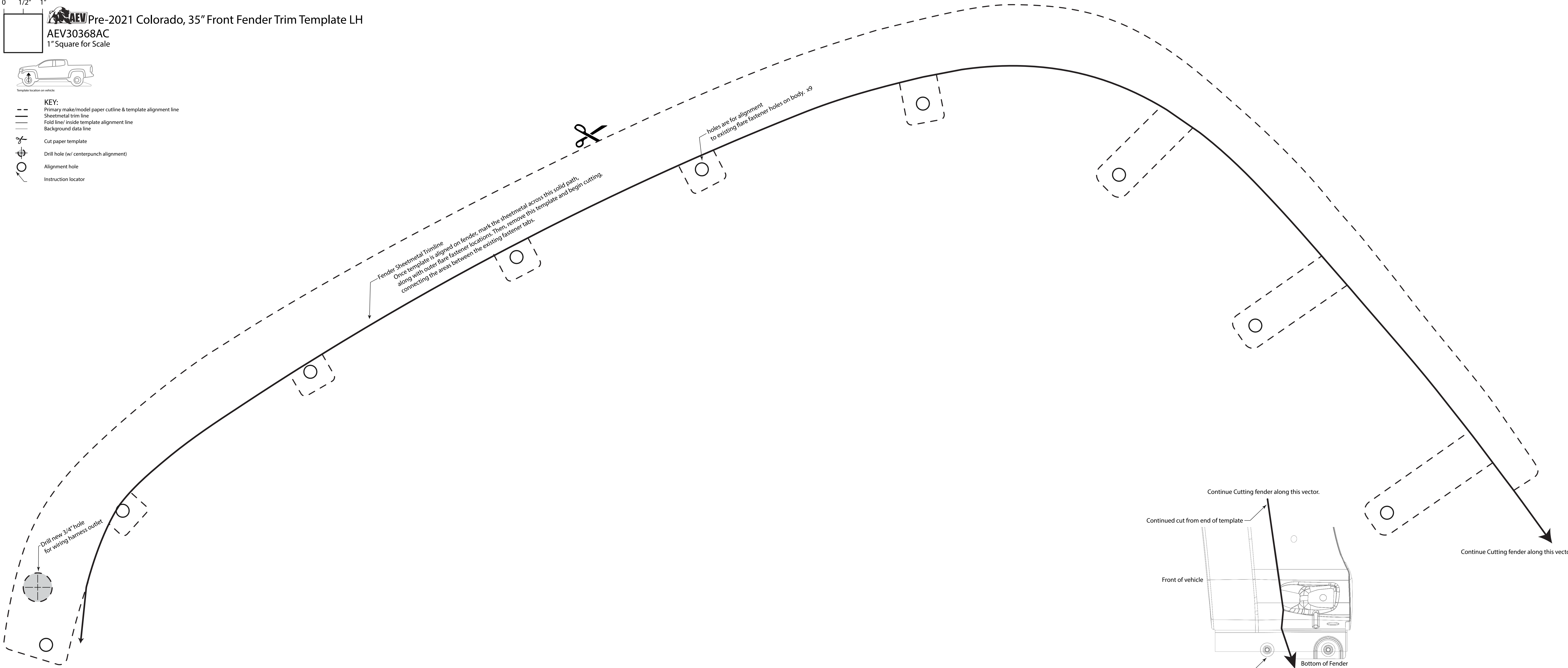

Drill new 3/4" hole for wiring harness outlet

holes are for alignment to existing flare fastener holes on body. x9

Fender Sheetmetal Trimline
Once template is aligned on fender, mark the sheetmetal across this solid path, along with outer flare fastener locations. Then, remove this template and begin cutting, connecting the areas between the existing fastener tabs.

Continue Cutting fender along this vector.

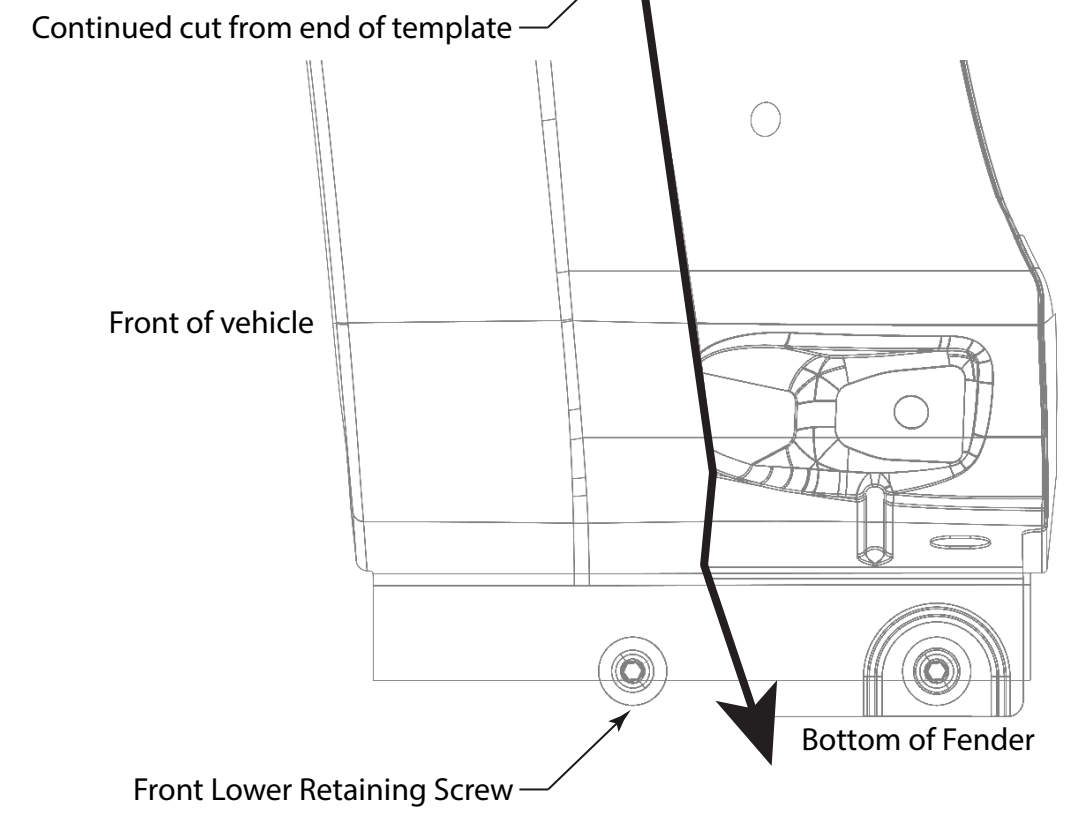

Continue Cutting fender along this vector.