



**BISON HEADLAMP  
FILLER PANELS**  
FOR CHEVY COLORADO



## PLEASE READ BEFORE YOU START

To guarantee a quality installation, we recommend reading these instructions thoroughly before beginning any work. These instructions assume a certain amount of mechanical ability and are not written nor intended for someone not familiar with auto repair.

INCLUDED PARTS	QTY	REQUIRED TOOLS
Headlamp Filler RH	1	Common Hand Tools
Headlamp Filler LH	1	Drill and 3/8" Drill Bit
Grill Gap Filler	1	Masking Tape
Hardware Pack	1	



## PRIOR TO INSTALLATION

If you are NOT installing AEV's Bison Fender Flares, have a body shop fill in the hole in the Headlamp Filler Panel prior to painting. We recommend using a proper plastic tab repair product.

Have the Headlamp Filler Panels painted professionally to match your Colorado's color. It is important to accurately tape off the lower step portion of the headlamp fillers.

## INSTALLATION

1. Use AEV template (AEV30316) applied to the bottom of the grill supports to mark and drill a hole on each side (fig. 1).
2. Install supplied M4 U-nuts onto the grill supports (fig. 2).

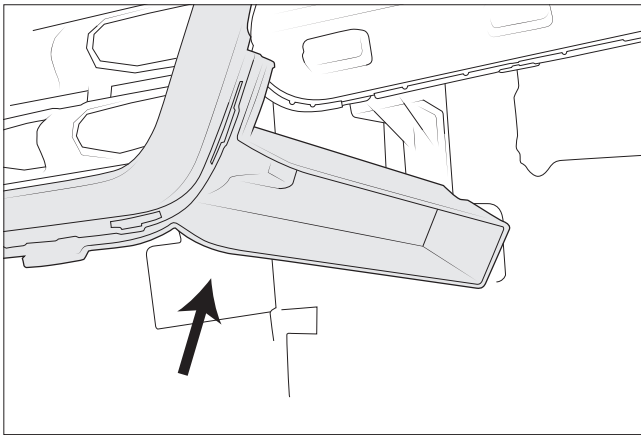

Figure 1

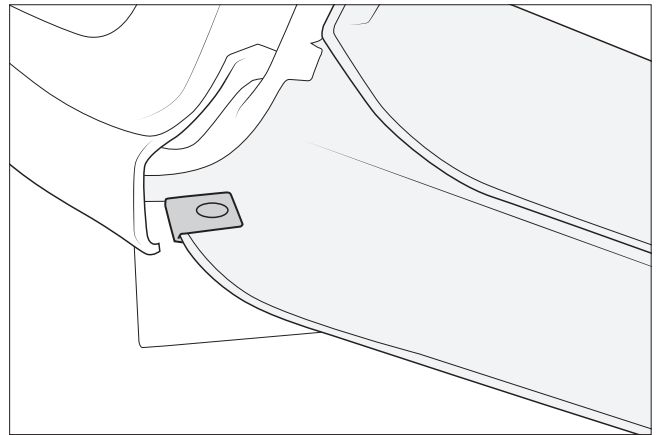

Figure 2

3. Install rubber Gap Filler by inserting tabs into the bottom of the grill working from the center outward (fig. 3).

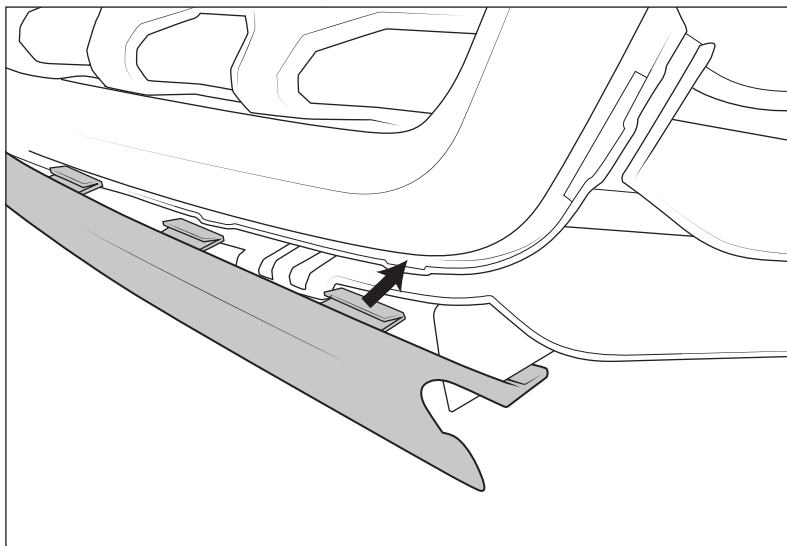

Figure 3



4. Install Headlamp Filler Panels.

A. Engage the pins on the Headlamp Filler Panel into the fender (fig. 4).

B. Snap the inboard side of the Headlamp Filler Panel into the grill (fig. 5).

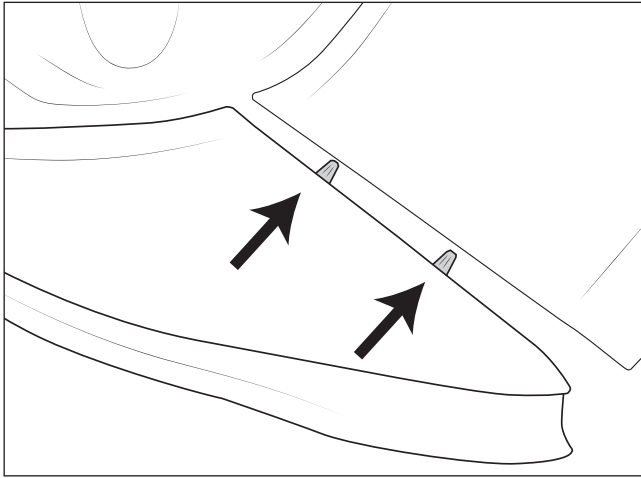

Figure 4

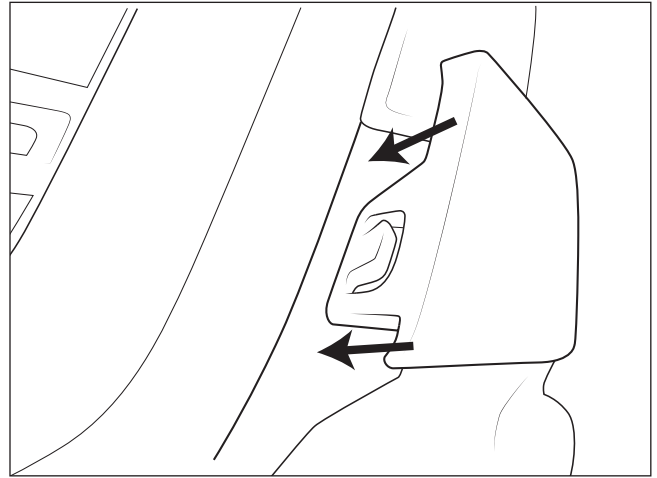

Figure 5

C. Install three 7mm hex screws (per side) into the filler panel under the fender (figure 6).

D. Install supplied flathead screws into the grill through the filler panel (figure 7).

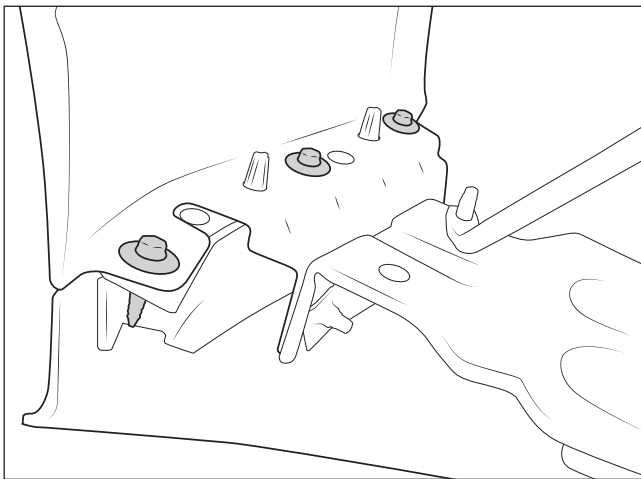

Figure 6

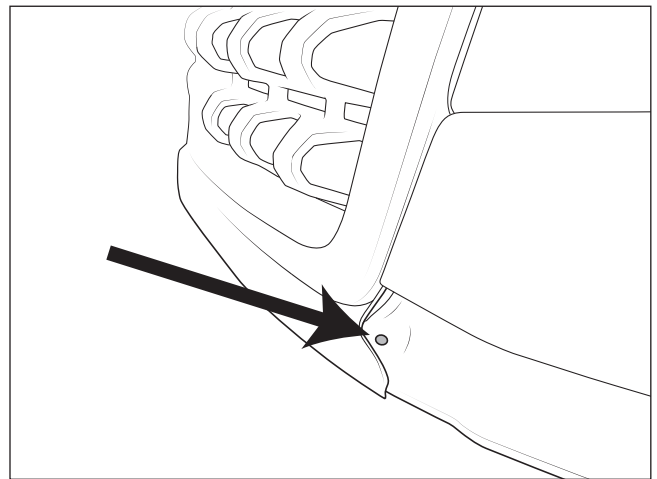

Figure 7



5. Trim Fender Flares( if not installing AEV Bison Fender Flares).

- A. Cut off the W Base Clip from the existing fender flare as needed so the flares will sit flush against the headlamp filler (fig. 8).
- B. Trim the front edge of the fender flares to sit flush (fig. 9).

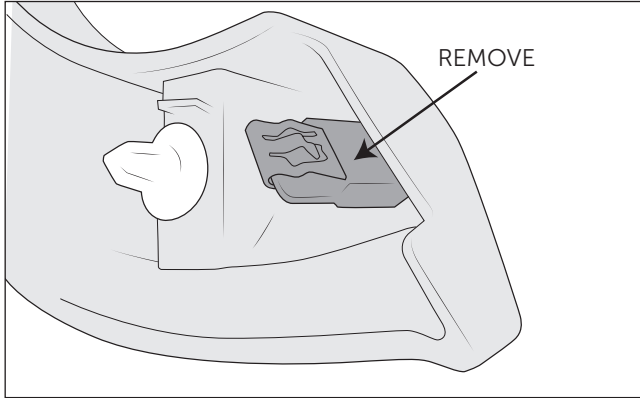

Figure 8

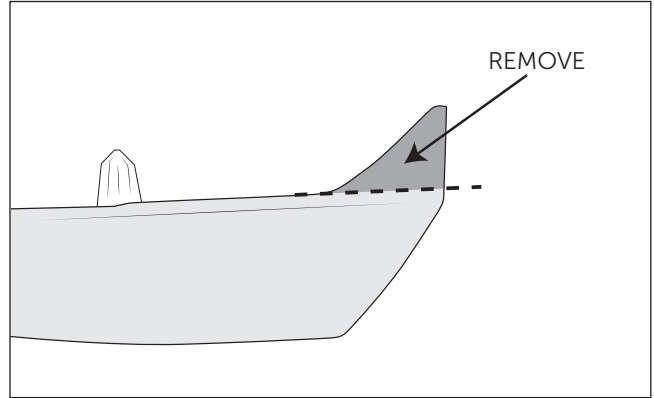

Figure 9

- C. Trim the bottom edge of the fender flares to sit flush with the paint ditch on the headlamp filler. This will allow an aftermarket bumper to flex without interference (fig. 10).

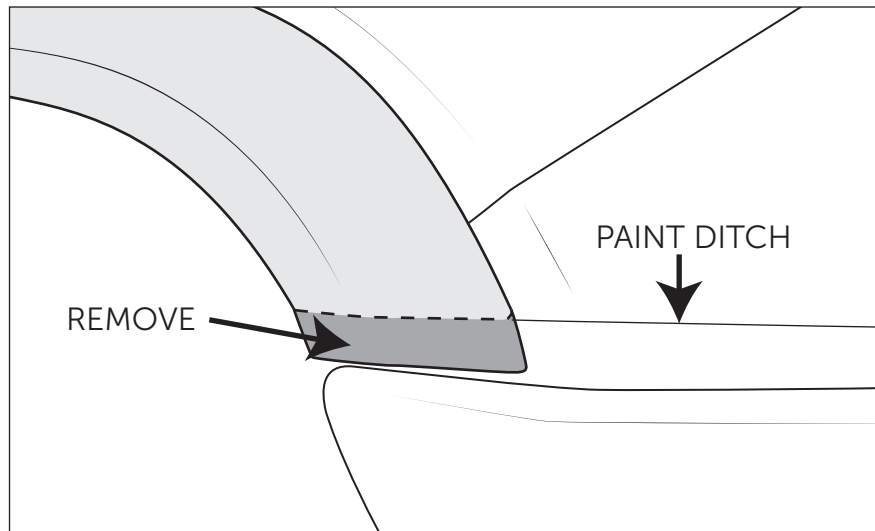

Figure 10

6. Install Aftermarket Bumper. NOTE: It is advised that you tape off the headlamp filler panels to avoid damage during bumper installation.