



BISON WINCH KIT

FOR WARN 9.5 XPS WINCH

INSTALLATION GUIDE



PLEASE READ BEFORE YOU START

To guarantee a quality installation, we recommend reading these instructions thoroughly before beginning any work. These instructions assume a certain amount of mechanical ability and are not written nor intended for someone not familiar with auto repair.

INCLUDED PARTS	QTY	REQUIRED TOOLS
Bison Winch Fairlead	1	Common Hand Tools
Controller Mount Bracket	1	
Wiring Harness	1	
Hardware Pack	1	



I. DISASSEMBLY

1. Disconnect and isolate the negative battery cable.
2. Remove Front Bumper Skid.
 - A. Remove the 4 M4 torx screws attaching the license plate bracket (fig. 1).
 - B. Remove the 2 M10 bolts in middle of Front Bumper Skid (fig. 2).
 - C. Remove the 4 torx bolts from bottom and sides of Front Bumper Skid (fig. 2).

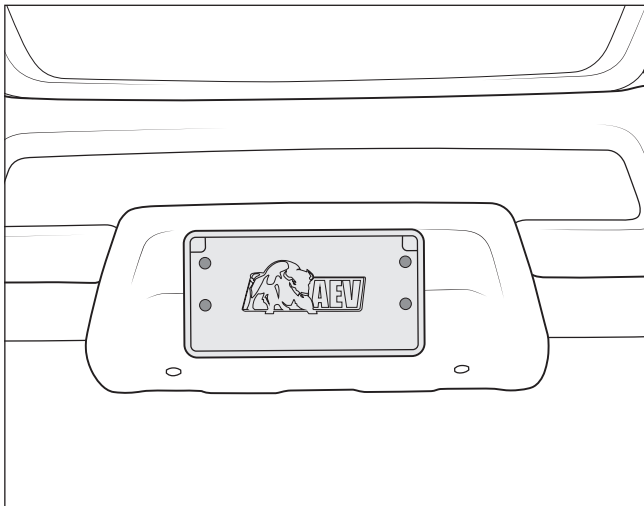

Figure 1

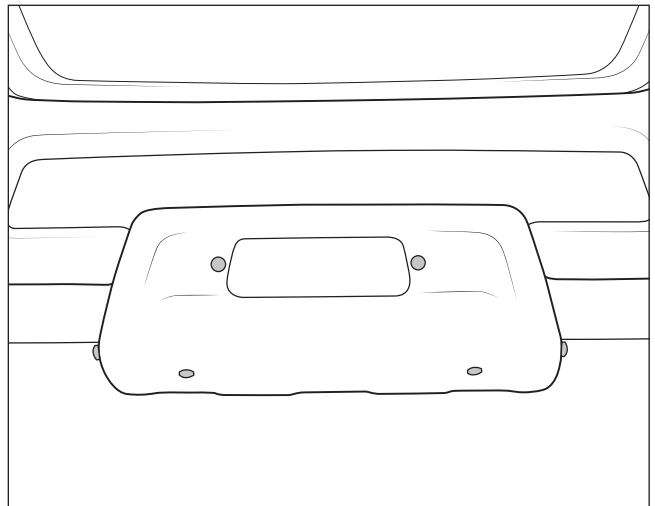

Figure 2

3. Remove Skid 1B by removing the 6 bolts (fig. 3).

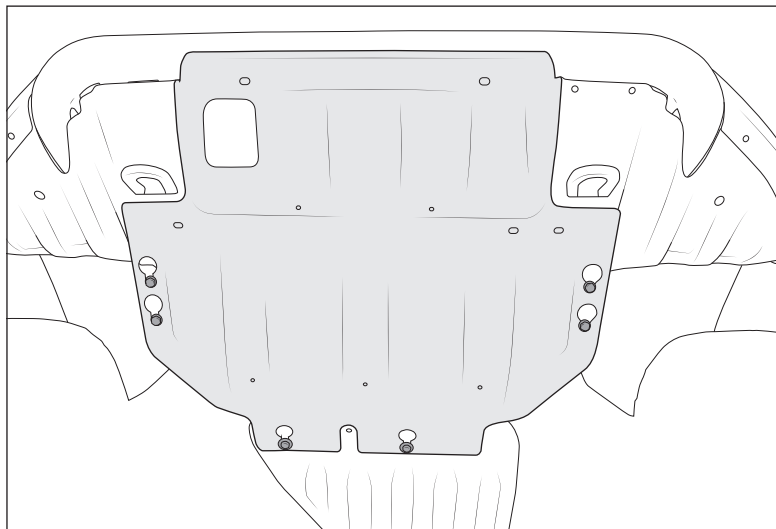

Figure 3



4. Remove the 6 M10 torx bolts attaching the center section of bumper (fig. 4).
5. Remove the 12 push clips attaching the air diverter (fig. 5).

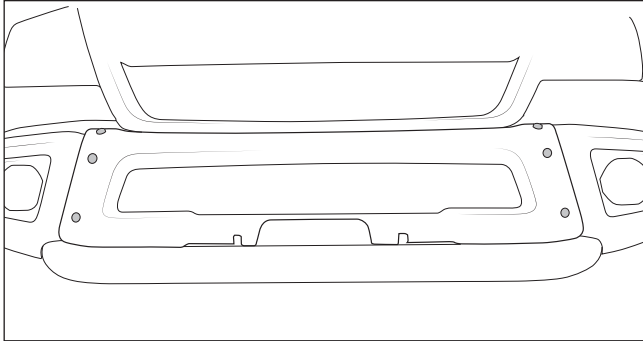

Figure 4

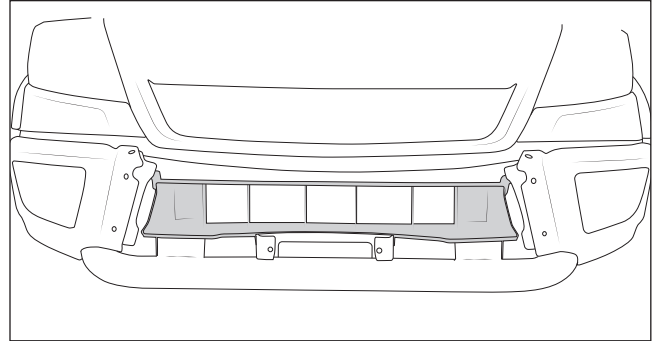

Figure 5

6. Remove LH and RH wheel liner closeouts (fig. 6).

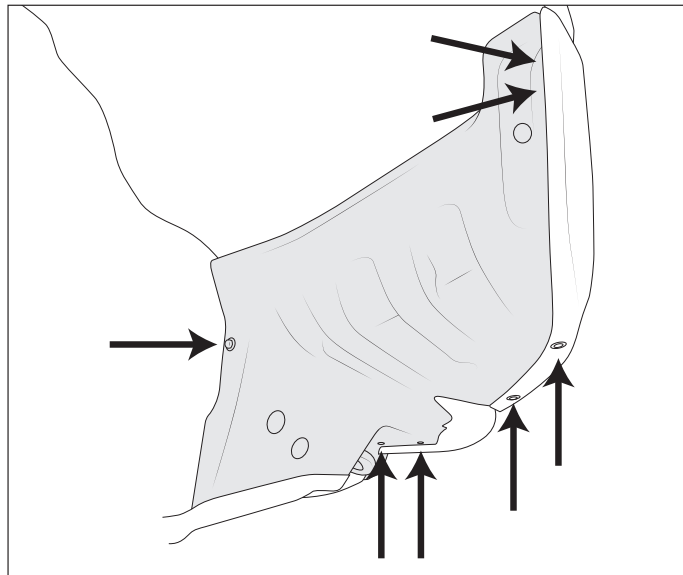

Figure 6

7. Remove Cage nuts in bumper for winch fairlead (fig. 7).

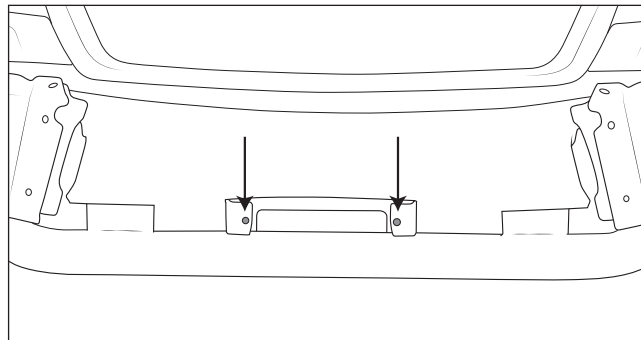

Figure 7



8. Remove 1 M10 bolt on radiator support and SAVE (fig. 8).
9. Remove 1 M6 bolt on radiator support and SAVE (fig. 8).
10. Un-clip radiator overflow hose (fig. 8).

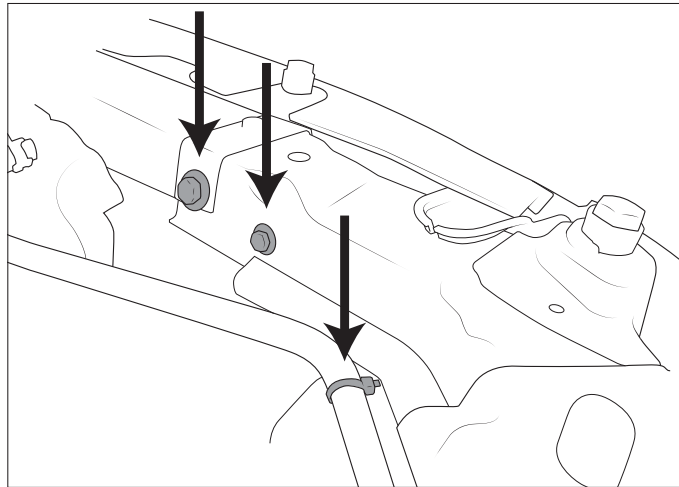

Figure 8

II. CONNECTING AEV WIRING HARNESS

1. Open Warn winch controller by removing QTY 4 bolts on bottom corners of controller (fig. 9).

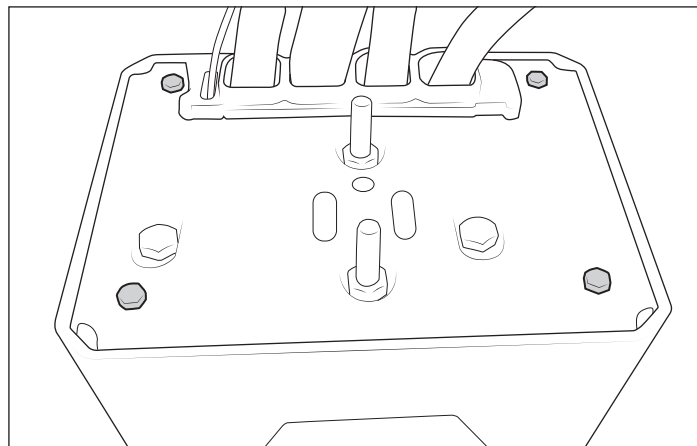

Figure 9



2. Disconnect the leads labeled A, F1, and F2 and remove the Warn harness from the controller (fig. 10).

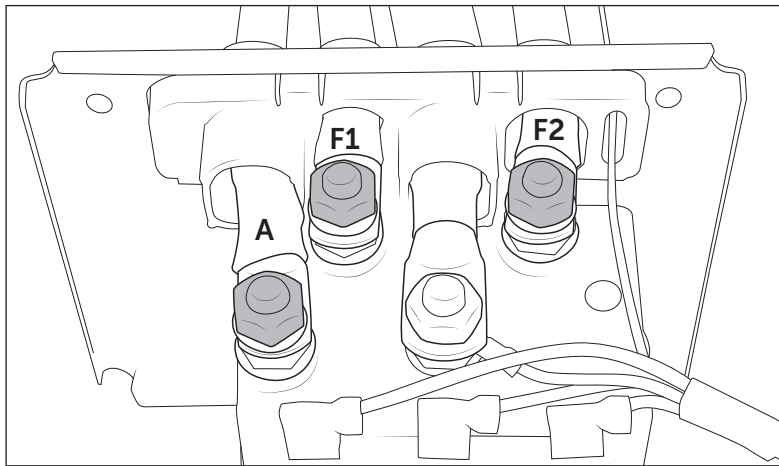

Figure 10

3. Route AEV harness through the AEV bracket and into the controller through the same openings the Warn harness was removed from.
4. Connect AEV leads. **Yellow = A, Green = F1, Blue = F2**
5. Isolate the small black motor ground wire inside the controller. Cut and splice in the new motor ground wire from the AEV harness. **NOTE: Make sure the splice will be located within the winch controller enclosure when reassembled.**
6. Mount the controller to the bracket using QTY 2 flange nuts provided on controller (fig. 11).
7. Reinstall QTY 4 bolts to reassemble controller housing.

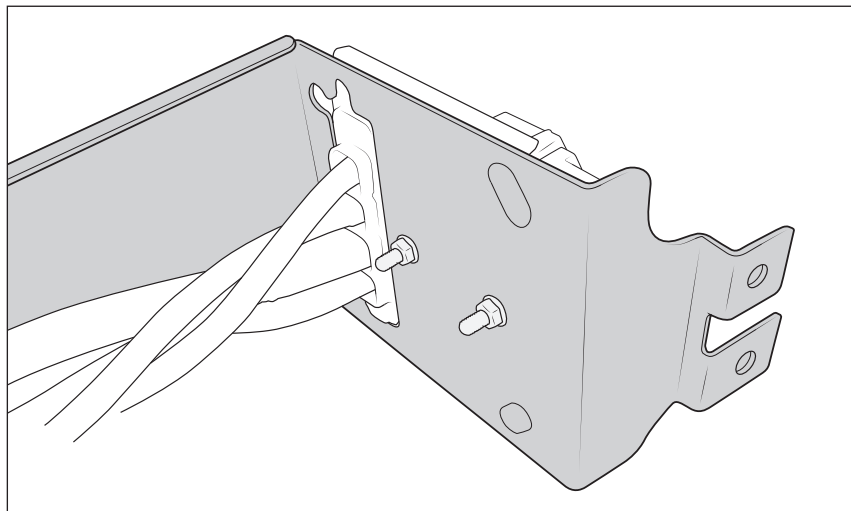

Figure 11



III. WINCH INSTALLATION

1. Set bracket into place in front of the airbox.
2. Position the controller bracket in place and loosely install the radiator support bolts removed earlier (fig. 12).

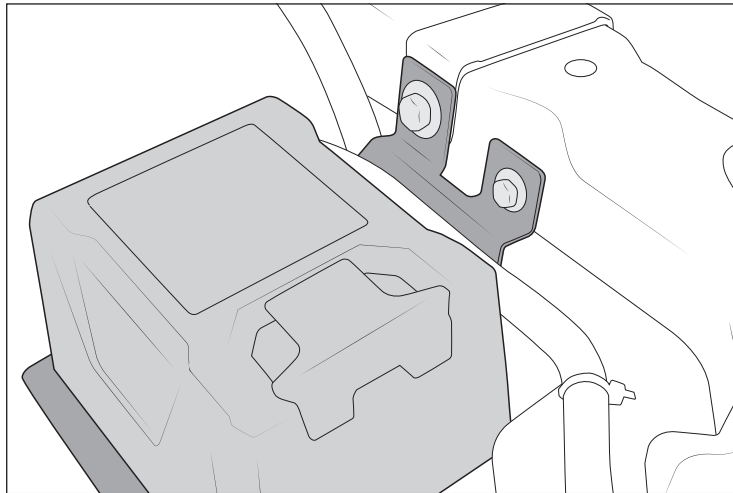

Figure 12

3. Install supplied bolt through the tab at the bottom of the bracket into the existing hole shown and secure with supplied flange nut (fig. 13).

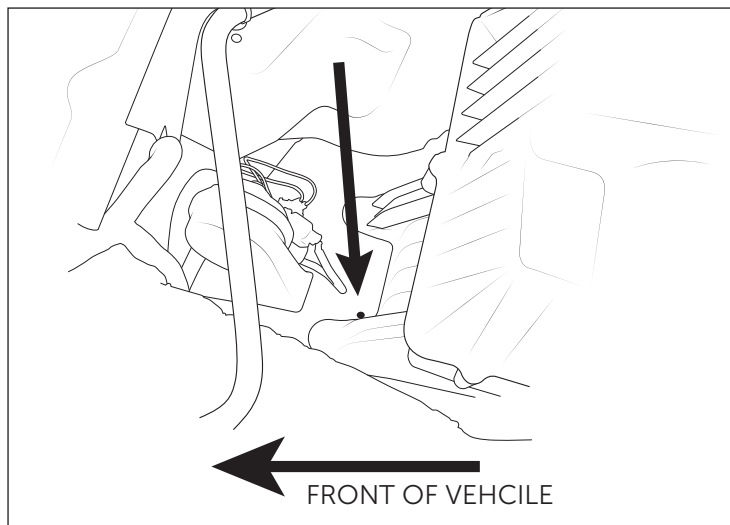

Figure 13

4. Route motor leads between the radiator shroud and inner frame rail, then through the gap between the radiator and the lower radiator support.



5. Run the wiring loom across the front of the vehicle. Detach the radiator supports to run the loom underneath as shown (fig. 14) then reinstall fasteners.

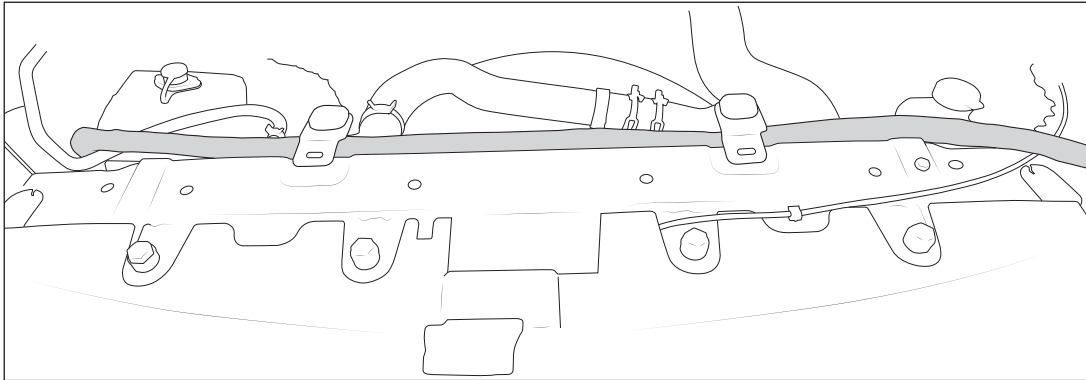

Figure 14

6. Route the Ground end of the harness through the bottom of the engine bay (fig. 14)

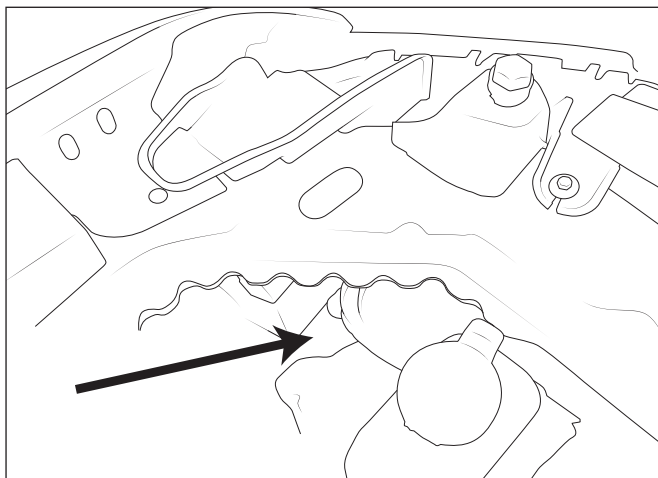

Figure 14

7. Route the battery leads toward the battery. **DO NOT** hook up at this time.
8. Install winch body (fig. 16).
 - A. Start 2 M10 x 4" bolts at the bottom of the winch.
 - B. Start 2 M10 x 1.75" bolts at the top of the winch.
 - C. Tighten bottom bolts.
 - D. Remove top winch bolts for now.

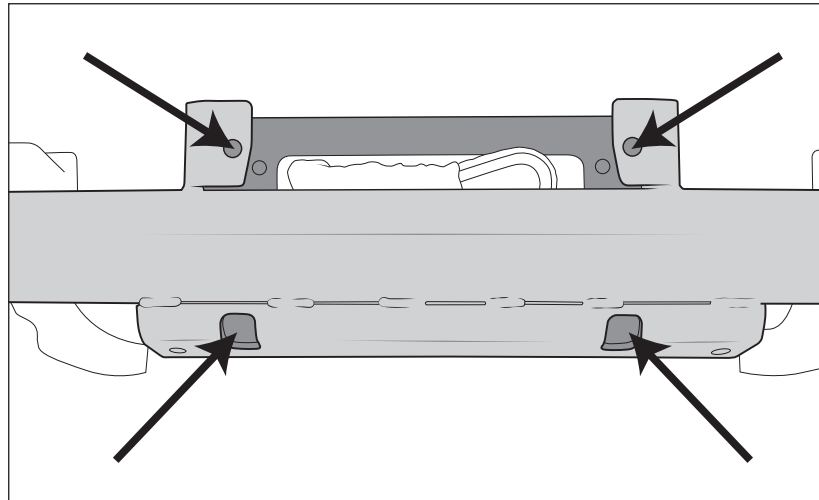
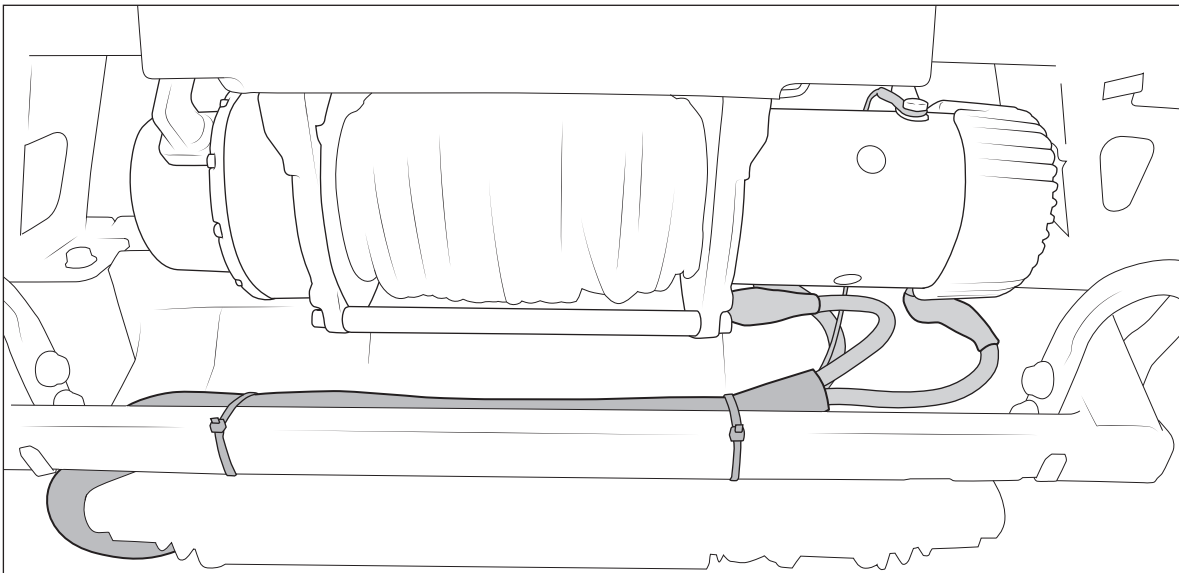

Figure 16

9. Connect wiring to winch.
 - A. Run the leads along the top side of the lower radiator support, securing with zip ties.
 - B. Connect the motor leads to the proper studs using the color to letter guide.





C. Attach ground wire.

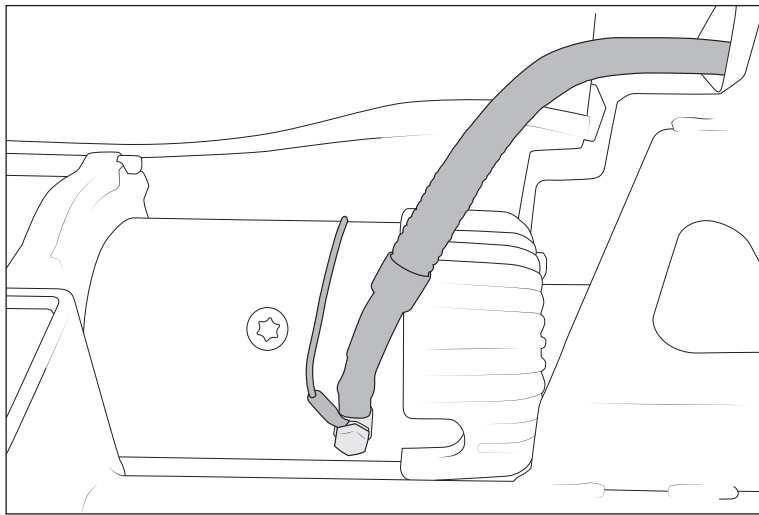

10. Run the winch cable through the Bison fairlead and drop into place (fig. 20).

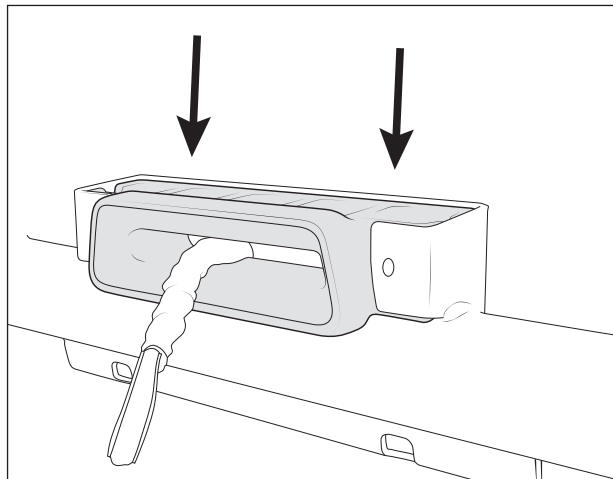

Figure 20

11. Trimming the air diverter (fig. 21).

- A. Using scribe line to cut air diverter for spool
- B. Reinstall air diverter with 12 clips

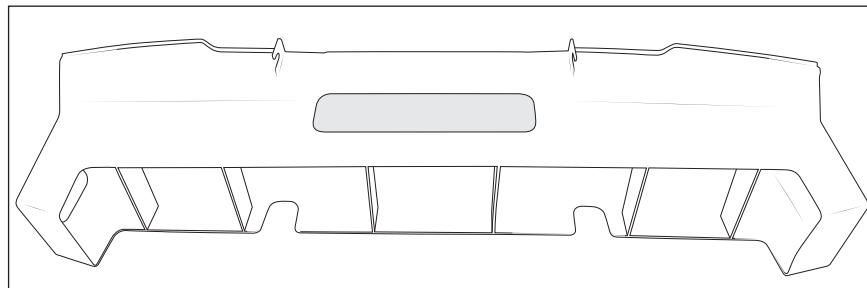

Figure 21



12. Reinstall Center section of bumper
13. Reinstall Wheel Liner Closeouts
14. Reinstall Skid 1B (fig. 3).
15. Reinstall Front Bumper Skid (fig. 2).
16. To mount a front license plate there are two options.
 - A. Follow drilling template AEV30343AA to mount license plate over fairlead. (fig. 22A).
 - B. Follow drilling template AEV30343AB to mount license plate curved under fairlead (fig. 22B).

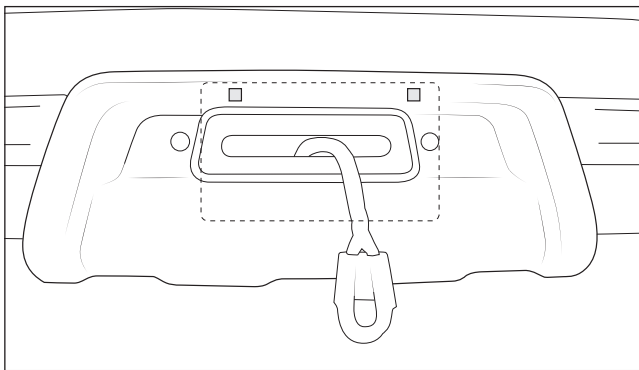

Figure 22A

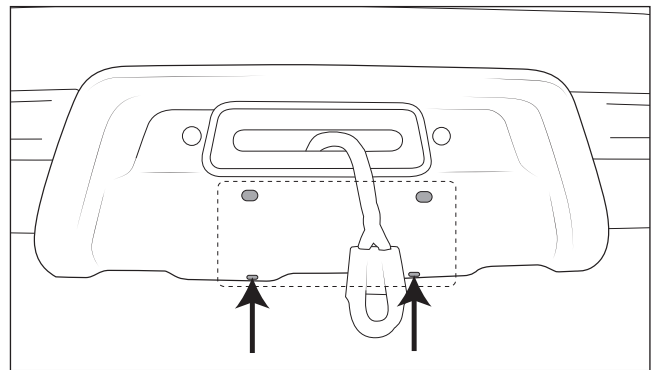

Figure 22B

17. Install winch hook per manufacturers recommendations.
18. Trim the battery box and lid to make space for the positive winch connection (fig. 23).

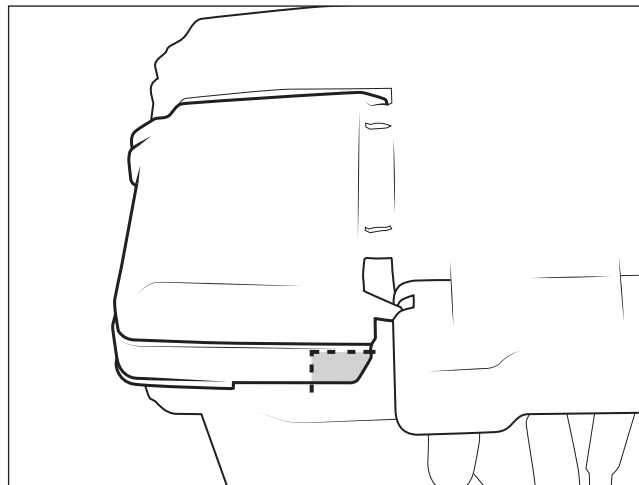

Figure 23



19. Attached positive line to battery.

20. 11. Route the negative lead alongside the battery and connect to the negative terminal (fig. 24).

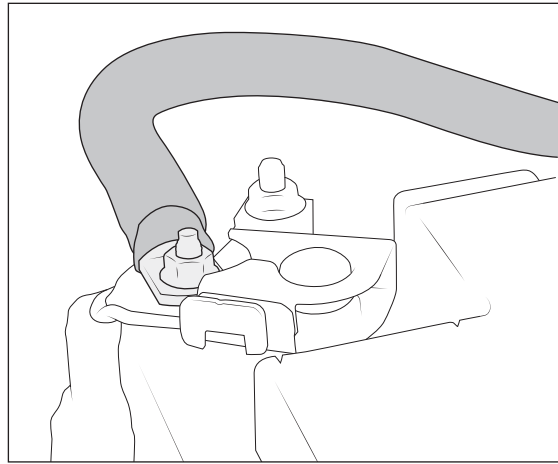

Figure 24

21. Spool winch according to manufacturers recommendations