



////////////////////////////////////

LICENSE PLATE MOUNT FOR ROLLER FAIRLEAD

PLEASE READ BEFORE YOU START

TO GUARANTEE A QUALITY INSTALLATION, WE RECOMMEND READING THESE INSTRUCTIONS THOROUGHLY BEFORE BEGINNING ANY WORK. THESE INSTRUCTIONS ASSUME A CERTAIN AMOUNT OF MECHANICAL ABILITY AND ARE NOT WRITTEN NOR INTENDED FOR SOMEONE NOT FAMILIAR WITH AUTO REPAIR.

INCLUDED PARTS	QTY	REQUIRED TOOLS
Molded License Plate Holder	1	Drill Motor
Molded Nylon Spring Clips	2	1/4" Drill Bit
Hardware Pack	1	Phillips Head Screwdriver



1. Place Molded License Plate Holder on a flat surface.
2. Use the template provided to drill two 1/4" holes where noted. Make sure the template is flush to the bottom and roughly centered on the License Plate Holder.
3. Mount the Molded Nylon Spring Clips to the back of the License Plate Holder (Fig 1.)
 - a. The top holes use only the #12 Pan Head screws.
 - b. The bottom holes use both the #12 Pan Head screws and the large washer.
 - c. Tighten the screws securely to the Molded Clips—Hand tighten only, No Power Tools.
4. Install the two Molded Nutserts into the License Plate Holder top slots (Fig 2.)
5. Install license plate into the License Plate Holder. Using the screws located in your vehicle's glove compartment, or the screws provided, secure the license plate to the License Plate Holder.

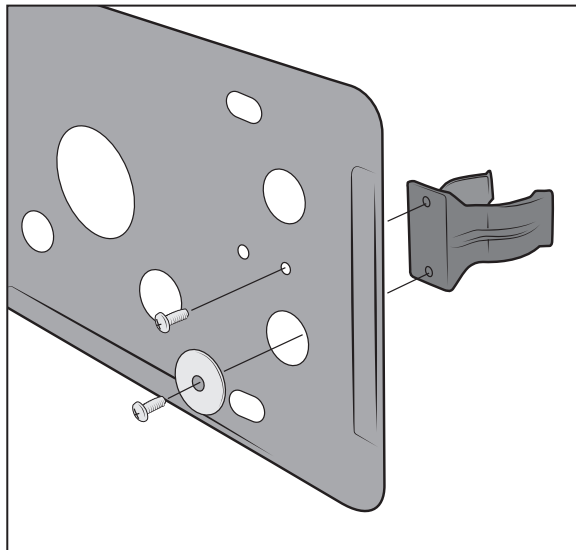

Figure 1

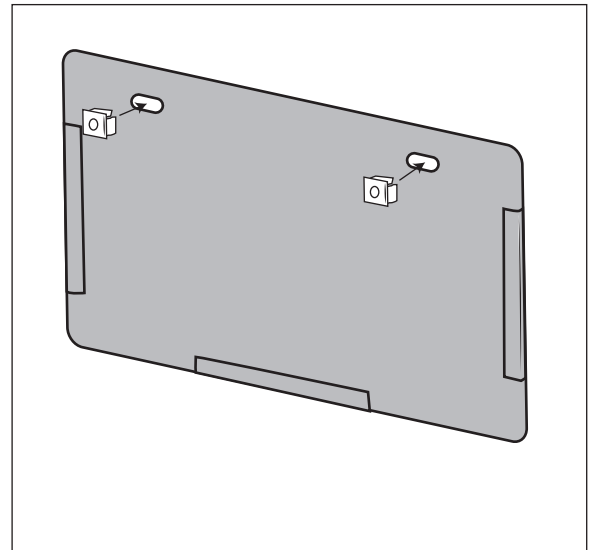
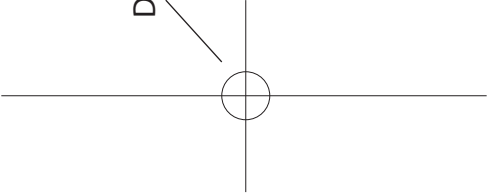
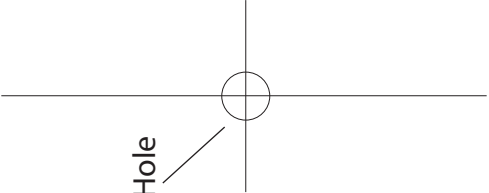
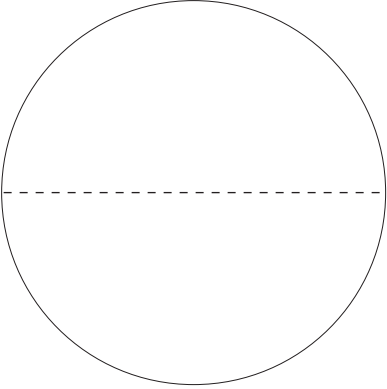

Figure 2

DRILLING TEMPLATE



BOTTOM



BOTTOM

