

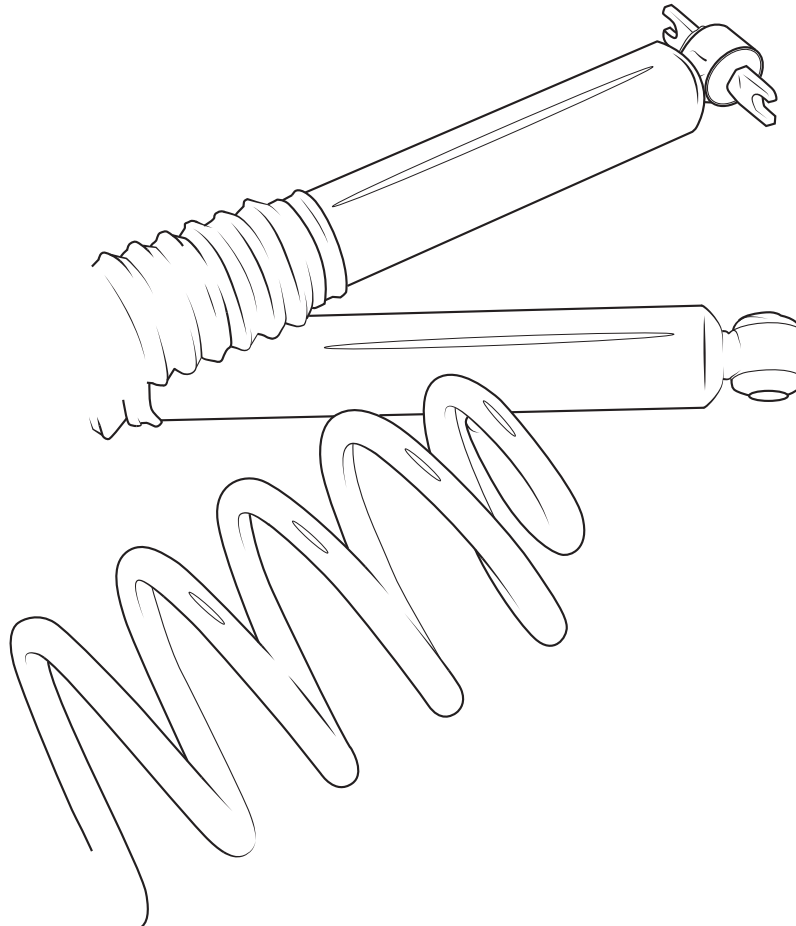

////////////////////////////////////

JK WRANGLER 3.5"–4.5" DUALSPORT SC SUSPENSION





PLEASE READ BEFORE YOU START

TO GUARANTEE A QUALITY INSTALLATION, WE RECOMMEND READING THESE INSTRUCTIONS THOROUGHLY BEFORE BEGINNING ANY WORK. THESE INSTRUCTIONS ASSUME A CERTAIN AMOUNT OF MECHANICAL ABILITY AND ARE NOT WRITTEN NOR INTENDED FOR SOMEONE NOT FAMILIAR WITH AUTO REPAIR.

INCLUDED PARTS	QTY	REQUIRED TOOLS
Springs	4	Basic Standard and Metric hand tools
Shocks	4	3/8-in Drill Bit
Bump Stop Spacer Kit	1	5/8-in Drill Bit
Rear Track Bar (LHD system only)	1	
Rear Track Bar Tower	1	
Brake Line Drop Bracket Set	1	
Rear Sway Bar End Links	2	
High Steer Kit	1	
Drop Bracket Kit	1	

Vehicle Applications 2007–Current Jeep JK Wrangler and Unlimited

Assumptions

Equipment that must already be present on your Wrangler

Stock JK frame and axles with all stock brackets intact.

2007–2011: Stock Exhaust-or equivalent position for clearance both where it crosses below the front driveshaft and over the rear tack bar.

2012+: An Exhaust modification is REQUIRED to clear the front driveshaft.

Stock Front and Rear Driveshafts

NOTE: Aftermarket units with double-Cardan joints will require a rear axle pinion angle adjustment that is NOT provided in these systems.

NOTE: A small-diameter front driveshaft is recommended for clearance on 3.5"/4.5" systems and all 2007–2011 vehicles with automatic transmissions.

NOTE: 28–30 PSI is AEV's recommended tire pressure with our Suspension Systems.

Aftermarket Wheels—These are recommended both for adequate width to mount large tires and decreased backspacing for chassis and steering clearance.

NOTE: JK Sport factory 16-in wheels will NOT clear the new drag-link included in all Premium Suspension Systems. Any AEV JK wheel will solve the clearance issue or a set of 1.0-in thick wheel spacers with your stock wheels.

NOTE: Wheels with extremely negative offset may negatively affect ESP.

Install Time (Estimated)

Home/DIY/Shop 1st Install: 10–12 man/hrs; Shop 2nd or later install: 7–8 man/hrs.

Please take the time to read these instructions—*They are long because we want you to get the installation right the first time and enjoy the product immediately thereafter!* DO NOT start or attempt this product installation if you are unsure of your abilities or do not have the resources listed above. Be sure to check all specified torques with a torque wrench...too tight is not just right!!



REAR SUSPENSION

1. Raise Jeep and support the frame using jack stands or a hoist, such that the rear axle can be lowered enough to remove the springs. Support the axle by placing floor jack under the center of the axle. Remove the wheels (Fig. 1).
2. Loosen but DO NOT remove all 8 control arm bolts. Detach parking brake cables from axle (Fig. 2).
3. Remove and discard the parking brake cable bracket (Fig. 3). On 4-door models the parking brake cable will need to be re-routed BELOW the frame cross-member. Reattach parking brake cable at axle.
4. Remove the track bar.
5. Remove Axle Vent from axle.

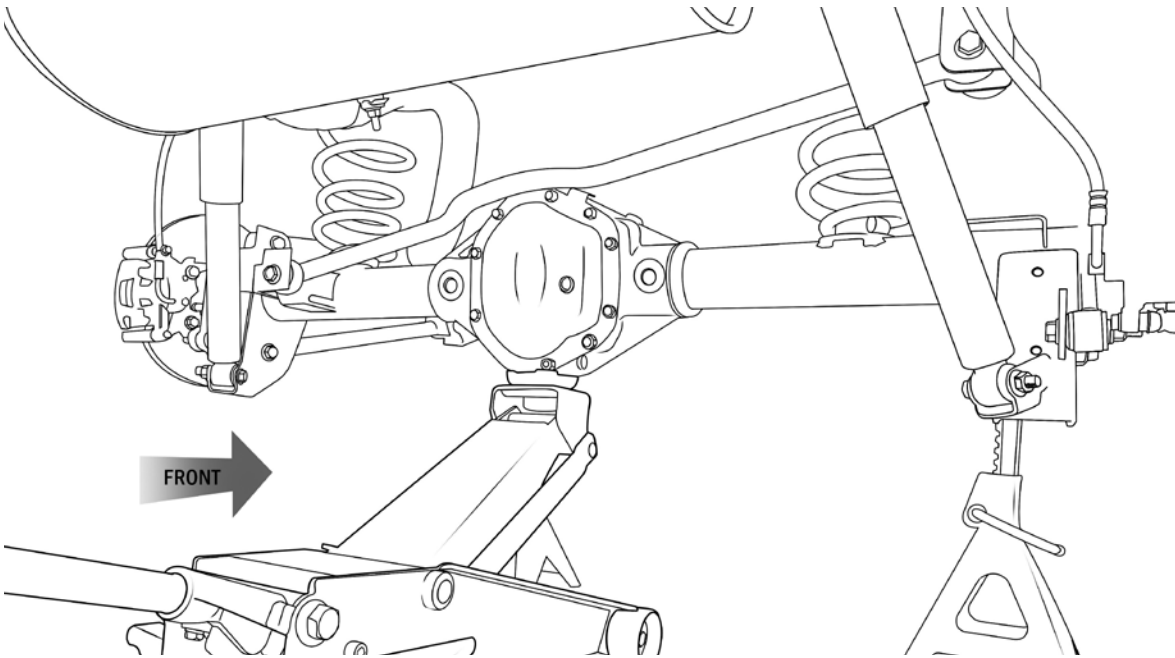

Figure 1

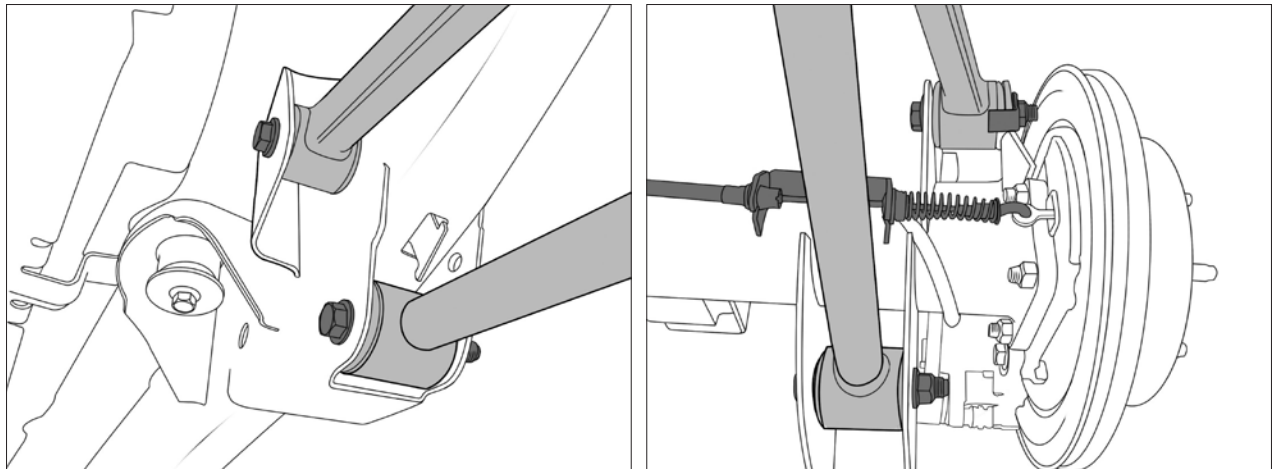

Figure 2

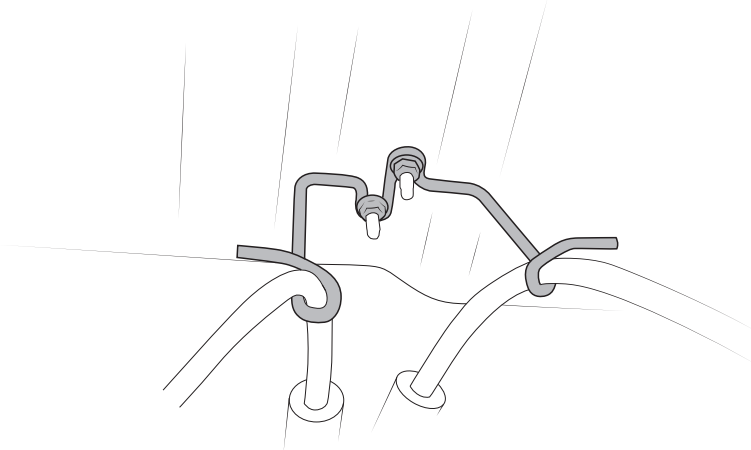

Figure 3

6. Remove the bolts that hold the brake lines to the frame (Fig. 4 A).
7. Remove the shocks (Fig. 4 B).
8. Remove the sway bar end links and save. You will reuse the hardware for the rear and the end links will be installed on the front of the vehicle. Note the orientation of the end links, the new end links will be installed in the same way (Fig. 4 C).

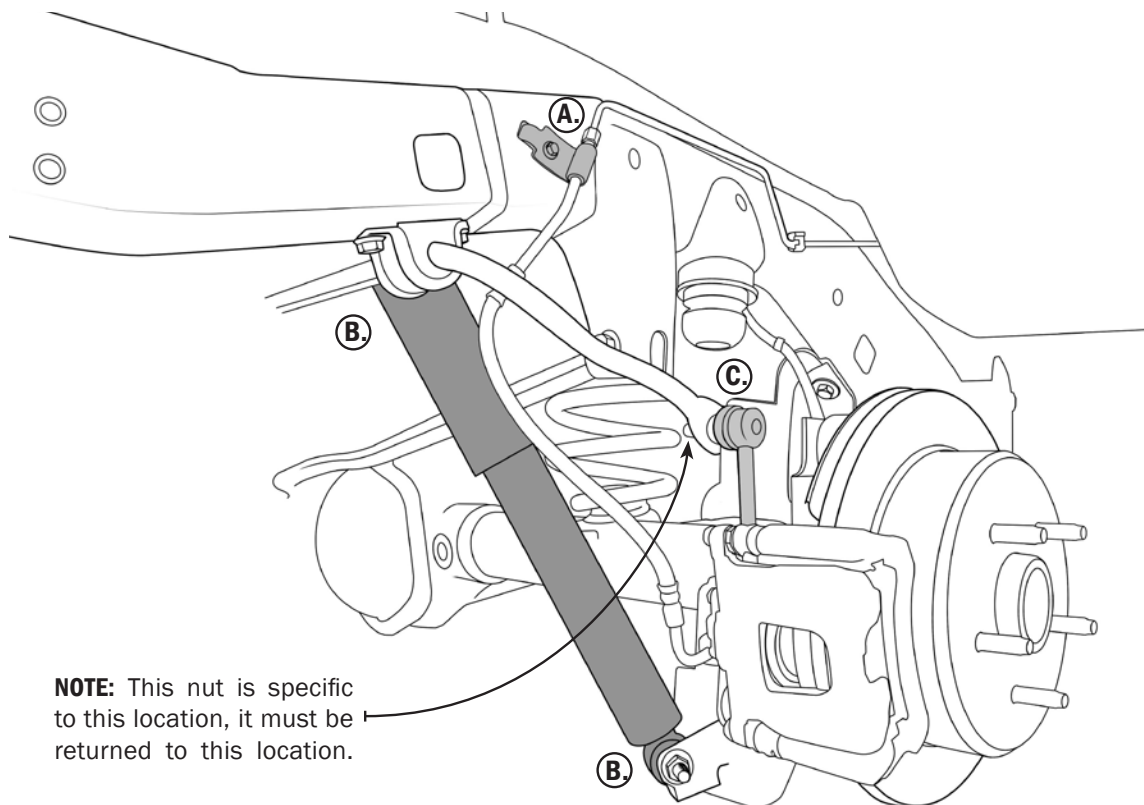

Figure 4



9. Carefully lower the axle using the floor jack enough to remove the springs. DO NOT overextend the wheel speed sensor or locker wiring, we recommend detaching the plastic fir tree cable ties from the axle and frame to allow sufficient movement. This pertains to wheel speed wiring and locker wiring if equipped.
10. Remove the factory springs.
11. Install the track bar tower.
 - A. Position the rear track bar tower on the axle and mark the hole as shown. (Fig. 5)
 - B. Remove the tower and drill the hole to 5/8"
 - C. Install the track bar tower with the supplied hardware in the orientation shown. Use 2 of the 1/2" washers as spacers as shown (Fig. 6). DO NOT TORQUE THE U-BOLTS TO MORE THAN 40 ft-lbs.
12. Install the new rear track bar hand tight as shown. This will be tightened later at ride height. (Fig. 6). NOTE: The trackbar bolts will be reinstalled in the opposite direction from factory (B.) Use the lower mounting hole for 3.5" suspensions (shown) and the upper for 4.5" suspensions.

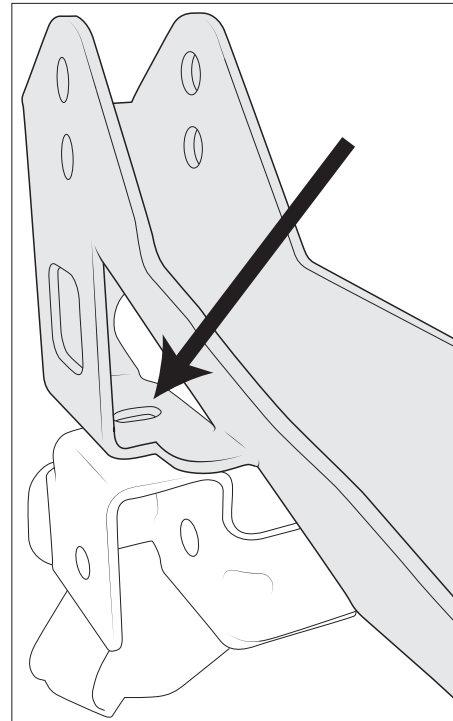

Figure 5

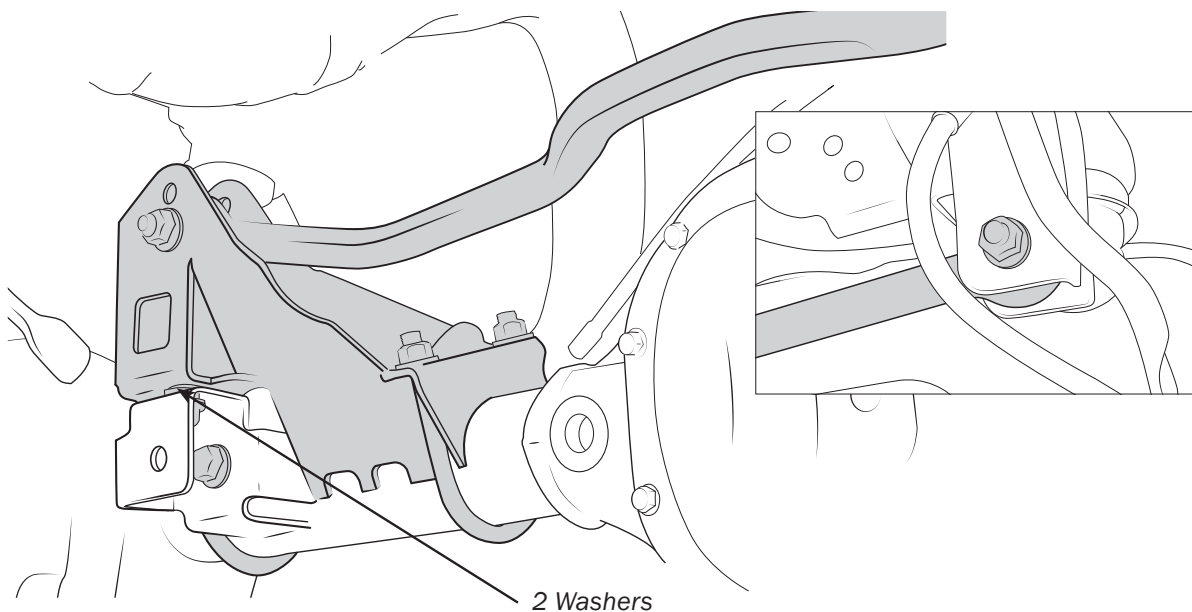

Figure 6



13. Install AEV springs making sure to properly index them on the axle spring seat (Fig. 7).

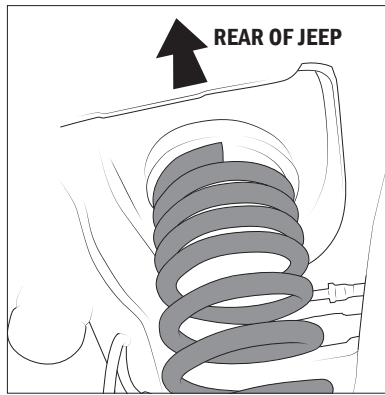

Figure 7

14. Install new shocks at upper mount. **NOTE: If installing Remote Reservoir Shocks, refer to Figure 8 for proper orientation to prevent damage to reservoir hose. It is critical that the hose for the remote reservoir shocks do not come into contact with any other parts. Remember that the shock will move as the axle travels through its range of motion, so you must be very diligent in the routing of this hose.**

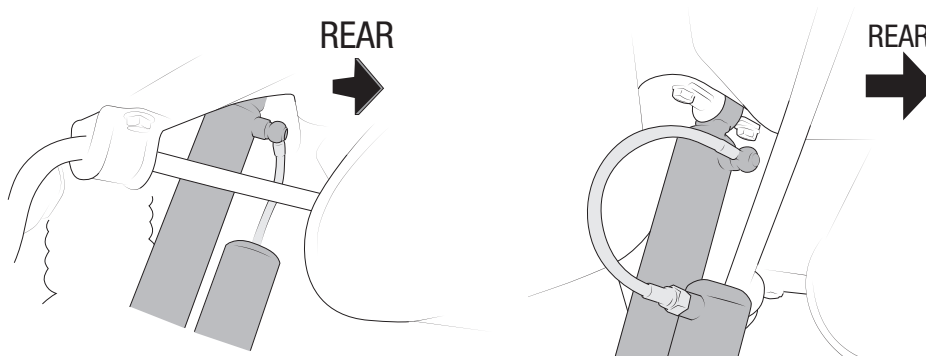

Figure 8

15. Raise axle slowly and guide springs into position.

16. Install AEV sway bar end links and tighten.* Re-install lower shock nut and bolt and tighten* (refer to Fig. 4-B.) Install brake line drop brackets as shown (Fig. 9) and tighten.*

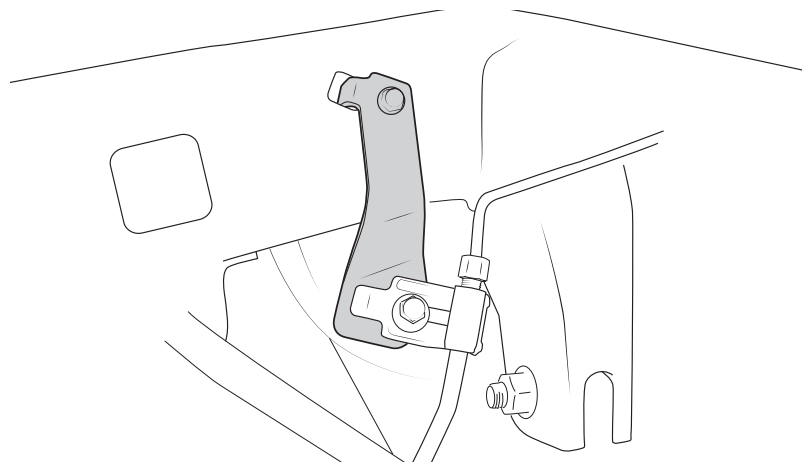

Figure 9

*Refer to Appendix for proper torque specs



17. Reroute the Axle Vent as shown (Fig. 10).

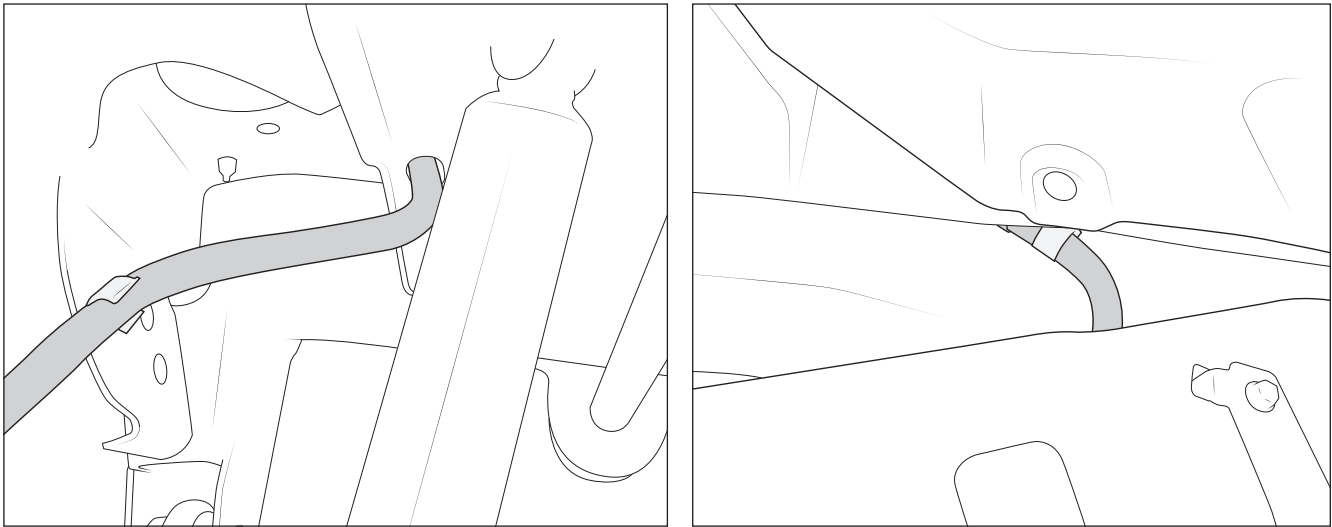

Figure 10

18. For **2007–2013** JK and JKU it is necessary to trim the pinch seams (and rocker guards on Rubicon models) if running 35" tires or larger. (Fig. 11). For **mid-2013 and newer** JK and JKU only the Rubicon rocker guard needs to be trimmed. Remove the end cap and trim 1" (from rear). Follow standard touch-up painting procedures to prevent corrosion on all cut surfaces.

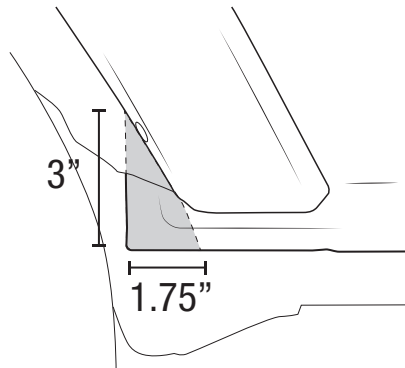

Figure 11

19. Reinstall wheels and tighten lug nuts, working in a star pattern.*

DO NOT install the rear bump stop spacers at this time. These will be installed after the control arms are torqued at ride height.

It is time to install the front suspension, however DO NOT tighten track bar or control arms at this time. These will be torqued AFTER the front suspension is complete.



FRONT SUSPENSION

1. Raise Jeep and support the frame using jack stands or a hoist, such that the front axle can be lowered enough to remove the springs. Support the axle by placing floor jack under the center of the axle. Remove the wheels (Fig. 12).

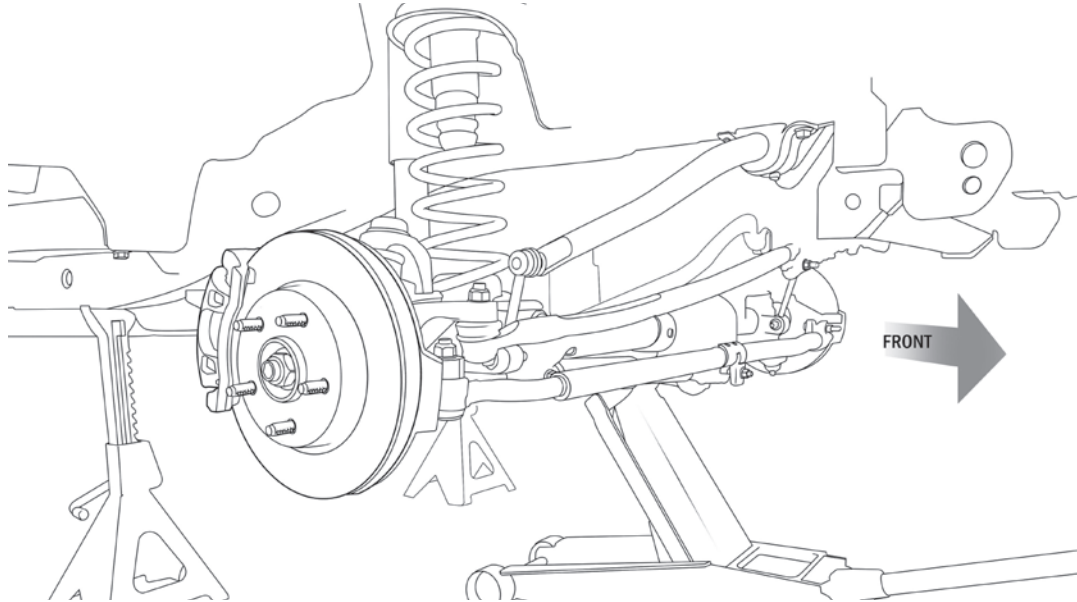

Figure 12

2. **Disconnect the drive shaft at the Axle end.** Make sure to mark both sides of the connection so you can properly align it when you reconnect it (Fig. 13). Tie loose end of the drive shaft up so it will not hang down. **Failure to follow this step may result in damage to your drive shaft.**

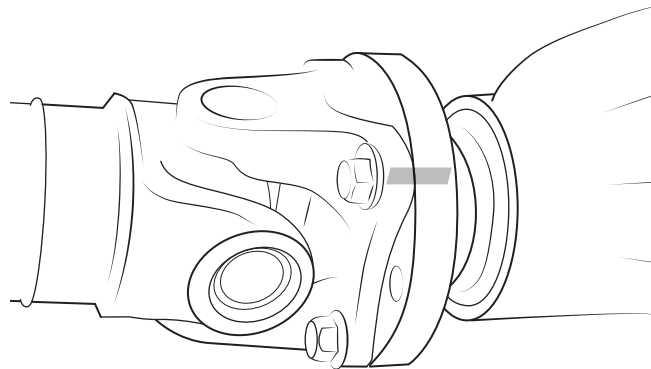

Figure 13

3. Remove the automatic transmission skid plate and set aside.
4. Loosen but DO NOT remove all 8 control arm bolts.
5. Remove the following parts:
 - Steering drag link (coupler to knuckle portion only)
 - Steering damper
 - Tie rod



- On **2007-2010** models only, loosen but **DO NOT** remove the frame-side track bar bolt. Remove and save the axle-side track bar bolt and flag nut (Fig. 14).

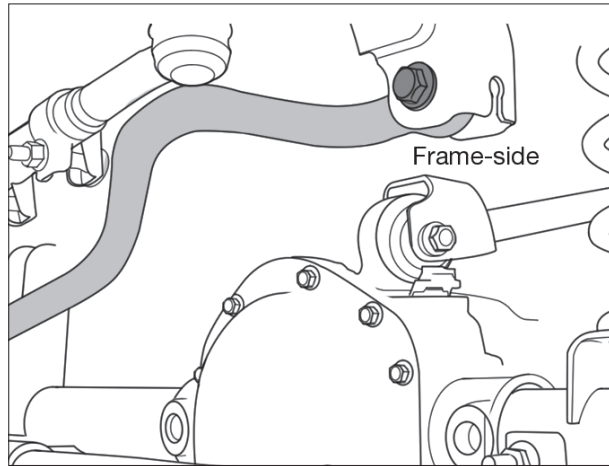

Figure 14

NOTE: On Rubicon models, remove the “fir tree” zip ties holding the speed sensor wiring to the upper control arm. On Rubicon models, unplug the locker connectors at the axle to keep from over extending the wires during install.

- Move the Axle Vent down and attach as shown (Fig. 15).

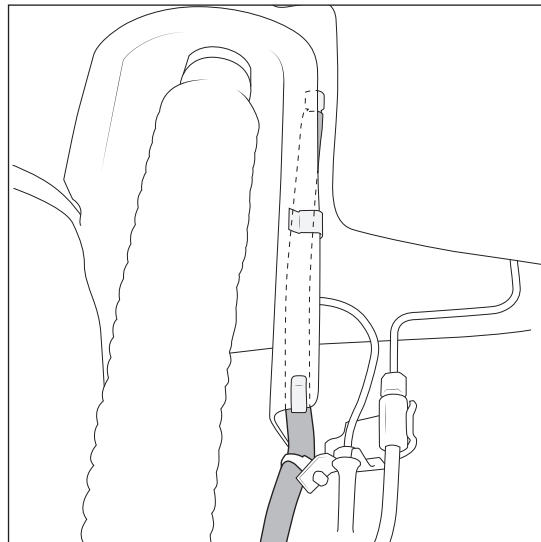

Figure 15



8. Remove and save all sway bar links and hardware. Note orientation, new links will be installed in the same way (Fig. 16)

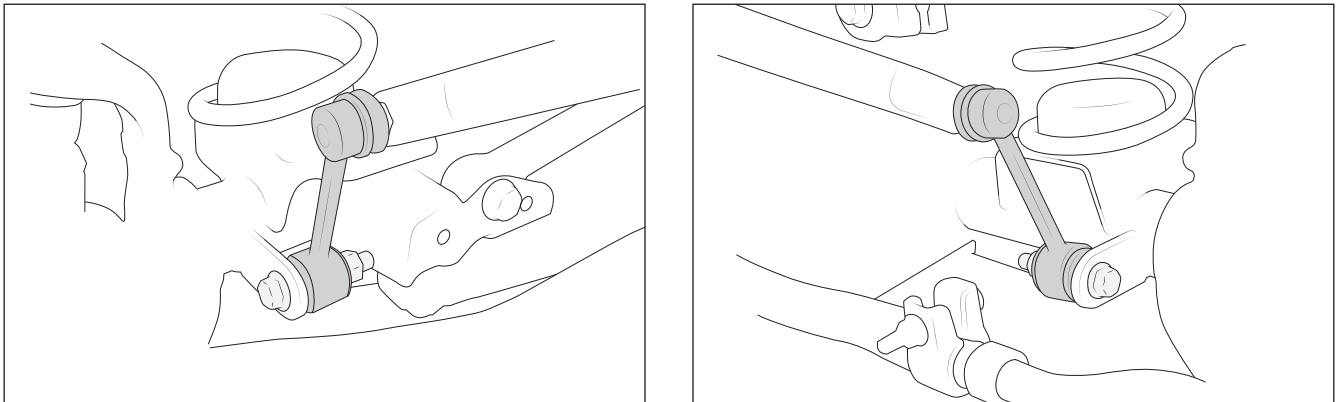

Figure 16

9. Remove shocks and save all shock mounting hardware.
10. For **2010 and older** models, remove the bolt holding the brake line to the frame.
11. For **2011 and newer** models, remove and discard factory bracket from the brake line (Fig. 17).

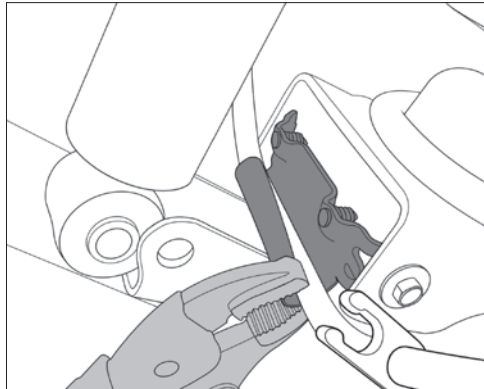

Figure 17

12. Lower axle and remove springs. DO NOT remove factory isolator.

NOTE: On most late model JK and JKU, there is a cross member tube extending far enough out of the frame to interfere with the front sway bar. We recommend trimming this just outbound of the weld (Fig. 18). Remember to follow proper painting procedures to prevent corrosion.

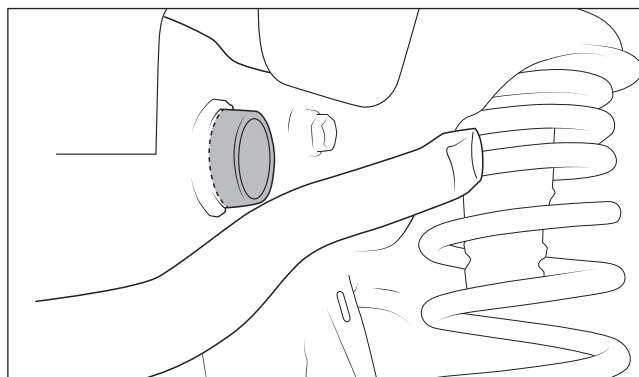

Figure 18



13. If you are installing Remote Reservoir Shocks install the reservoir bracket at this time (Fig. 19).

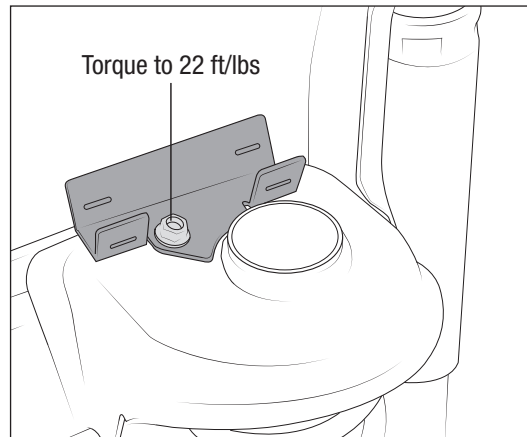

Figure 19

14. Install Track Bar relocation brackets.

- A. Place bracket with “half moon” cutouts inside the original front track bar bracket and over the axle tube (Fig. 20-A). Insert two of the supplied $3/8" \times 1.0"$ L bolts and washers through the small holes in the bracket and the corresponding holes in the stock bracket, then add nuts and hand tighten.

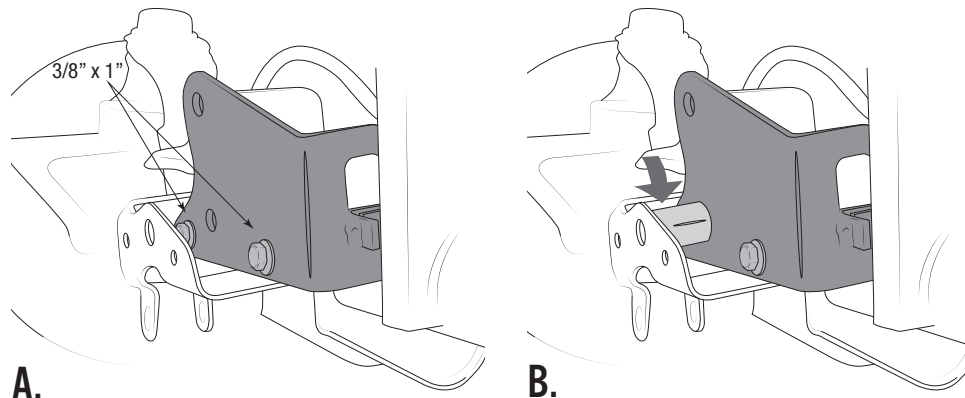

Figure 20

- B. Add the supplied u-bolt and nuts (visible in Fig. 22).
- C. Insert the supplied spacer tube between stock track bar bracket and new bracket (Fig. 20-B), lining it up with the original track bar bolt hole. (This may require slight prying or tapping with a hammer.)
- D. Pre-assemble the second bracket as shown (Fig. 21) with the supplied bolt, washers, and free-spinning nut.

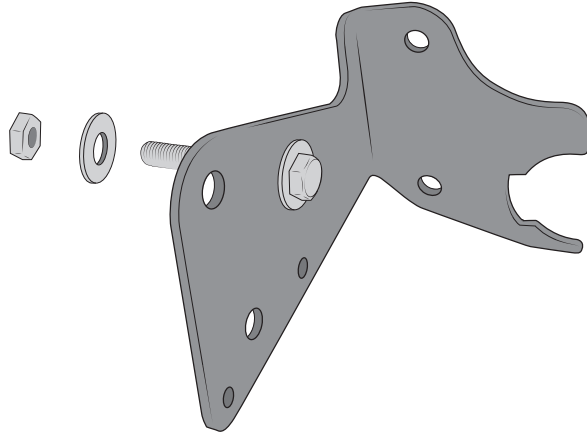

Figure 21

- E. Install this bracket in front of the stock track bar bracket on the axle and line up the small holes with the corresponding ones on the axle bracket. Insert the remaining two $3/8$ " x 1.0" L bolts and washers from the front through the brackets, add nuts and hand tighten.
- F. Insert the $1/2$ " x $1\ 1/2$ " L bolt through the factory stabilizer tab on the side of the axle and the corresponding bracket hole and add the locking nut.
- G. Place $9/16$ " x $3\ 1/2$ " L bolt through original track bar hole, both brackets, and supplied spacer tube.
- H. You may now tighten and torque all fasteners.

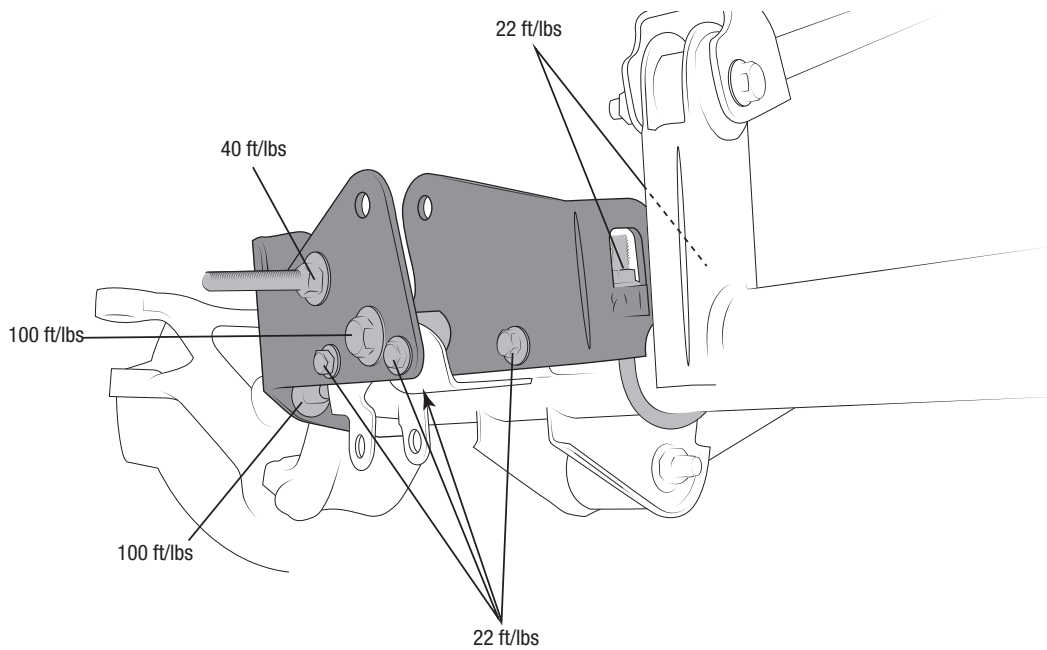

Figure 22



15. Install driver-side Swaybar relocation bracket. Position bracket over axle tube as shown (Fig. 23) Use the other supplied 1/2" x 1 1/2" bolt to attach bracket to axle and tighten to 100 ft-lbs.

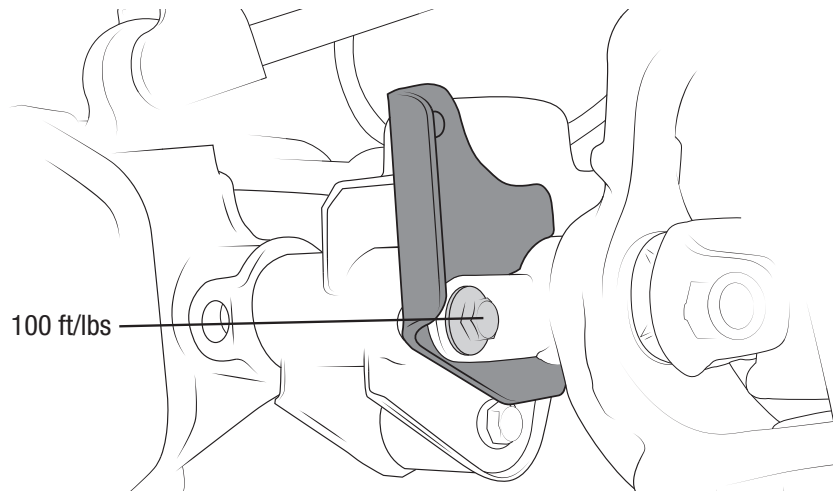

Figure 23

16. Reattach track bar

- A. Raise the axle until the axle-end of the track bar can be lined up with the uppermost holes in the new brackets (it may be necessary to pry the brackets apart to allow the track bar to drop in easily).
TIP: We find that using a ratchet strap to move the axle over will help with aligning the holes.
- B. Insert original track bar bolt and flag nut through passenger-side front axle brackets and track bar but do not tighten at this time (refer to Fig. 30).

17. Install Springs

- A. Drill a 3/8 inch hole in the center of the axle bump stop pad (Fig. 24-A).
- B. Place bump stop spacer inside springs (Fig. 24-B).
- C. Install AEV springs, keeping factory isolator in place. Make sure to properly index the springs on the lower spring seat.
- D. Install and tighten supplied bump stop spacer hardware. Torque to 22 ft-lbs.

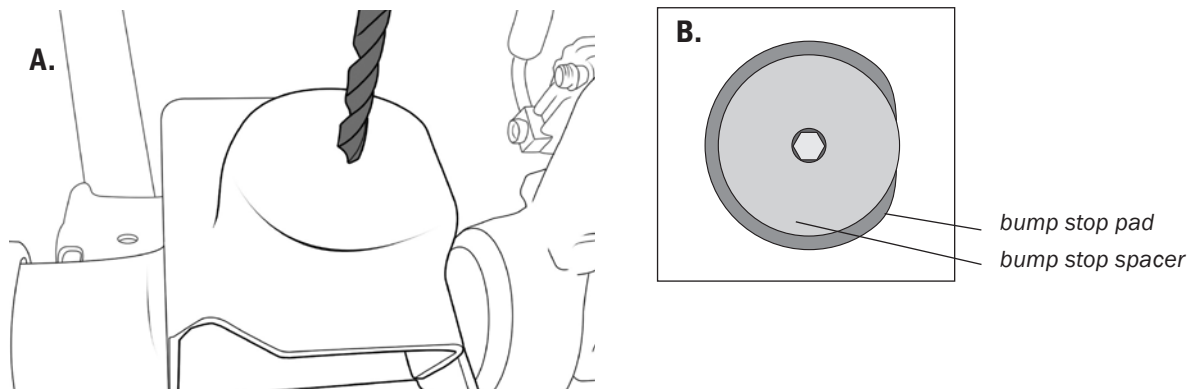

Figure 24



18. Install sway bar end links

- A. Use the factory REAR end links removed earlier or end links with the same overall length as factory rear JK or JKU end links.
- B. For each side attach the upper end stud to the sway bar in the same manner as the original front links had been (nut on frame side of bar). NOTE: The upper stud has a different thread than the rest of the M12 fasteners in the suspension—it is a “normal” pitch versus a “fine pitch.” Tighten to 40 ft-lbs. (refer to Fig. 16 for proper orientation.)
- C. The lower ends of the links will attach to the inboard side of the new brackets on the axle using the original hardware. Torque to 40 ft-lbs.

19. Install shock doubler brackets

- A. Install Shock Doubler brackets on both sides as shown using supplied hardware (Fig. 25).
- B. Install shocks in Shock Doubler brackets as shown using supplied hardware (Fig. 25).
- C. Install shocks in the upper mount. DO NOT over compress the bushings.
- D. If using remote reservoir shocks, use the supplied hose clamps to secure the reservoir portion of the shock into the bracket. CLAMP ROTATION IS CRITICAL, pay attention to prevent contact with the washer bottle (Fig. 26).

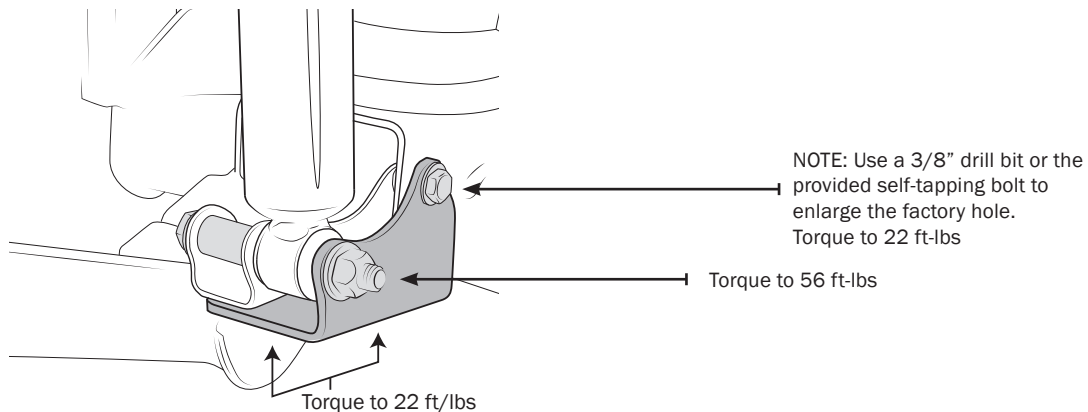

Figure 25

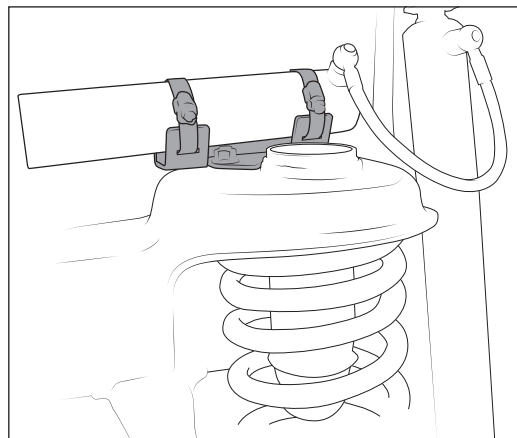

Figure 26



20. Install high-ster draglink

- A. Apply anti-seize compound to the threads of the new draglink and thread it into the adjuster sleeve until the amount of thread showing is similar to the amount showing on the short side that is still attached to the pitman arm.
- B. Twist the self locking tapered sleeve into the bottom of the knuckle mounting hole (the self-locking tapered sleeve is stored between the seal and the plastic seal shipping protective cover on the draglink outer end).
- C. Install the top mount draglink into the knuckle hole from the top side and tighten the nut until the nylock on the nut engages.
- D. Hold the hex, using a 10mm wrench, on the end of the ball stud to keep the stud from turning in the socket while tightening the ball stud nut using a 21mm wrench. Tighten until approximately 40 ft-lbs of torque is achieved. Once the 40 ft-lbs of torque is achieved, tighten to 125 ft-lbs using a 21mm socket.
- E. Grease draglink socket through the zerk until grease purges around the boot seal; wipe off excess grease.

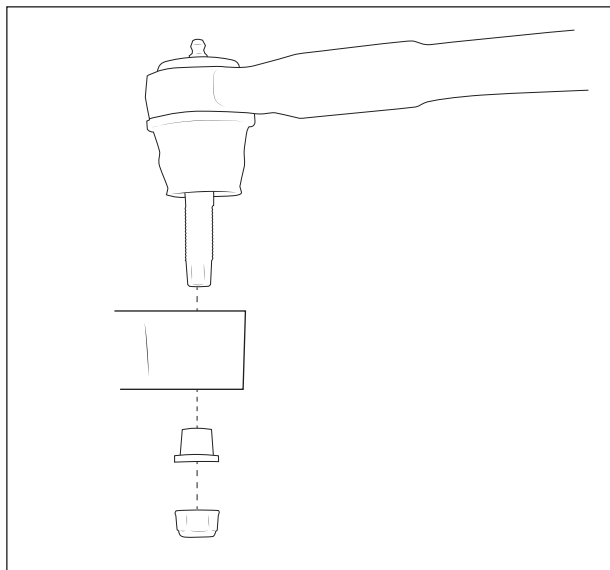

Figure 27

- F. Install tie rod. Torque both sides to 65 ft-lbs.

21. Install new steering damper

- A. To position the tie rod bracket properly, measure 19 1/4" from the edge of the tie rod tube to the center of the stud as shown. (Fig. 28) Rotate the tie rod bracket until the stud is pointing just forward of straight up. Tighten the mounting bracket at this location. After the mounting bracket is tight, tighten the factory steering stabilizer to bracket nut, torquing to 37 ft-lbs.
- B. Attach the damper to the new High Steer axle bracket orienting the hardware as shown (Fig. 29).
- C. Attach the damper to the factory tie rod bracket using one of the supplied 7/16" washers. Torque to 35 ft-lbs.

Rotate the black rubber boot on the damper so that the drainage holes are on the bottom.

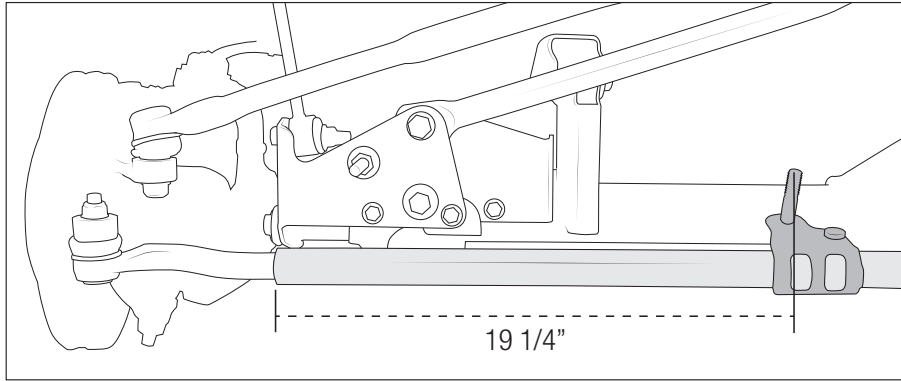

Figure 28

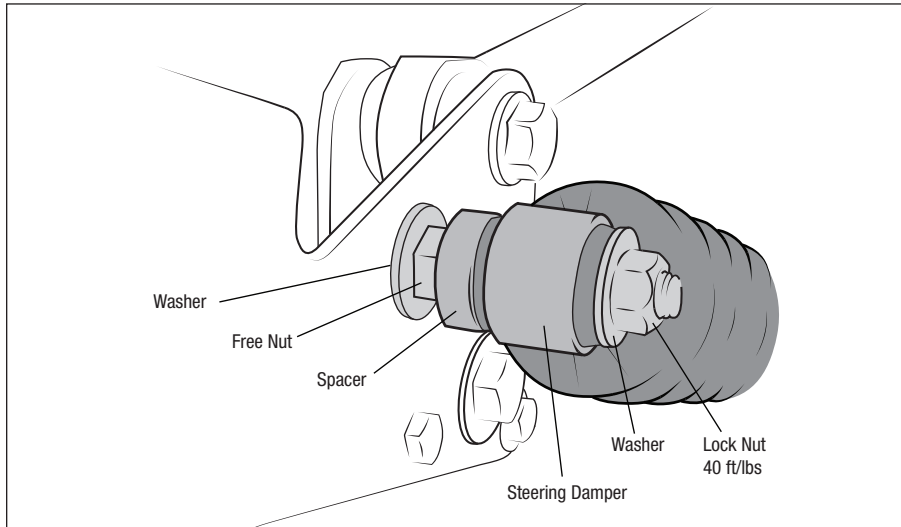

Figure 29

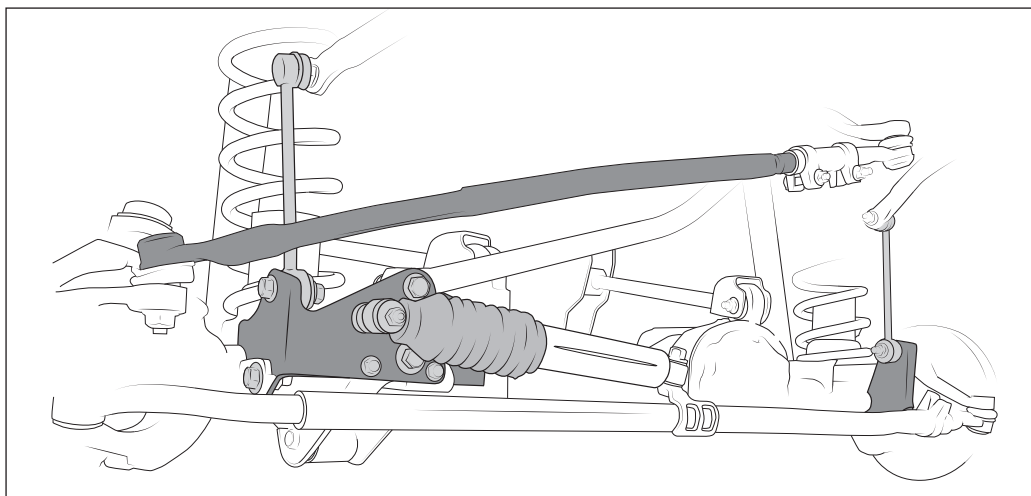

Figure 30



22. For **2007–2010** model year JK's install the front brake line drop brackets tightening to 8 ft-lbs (Fig. 31).

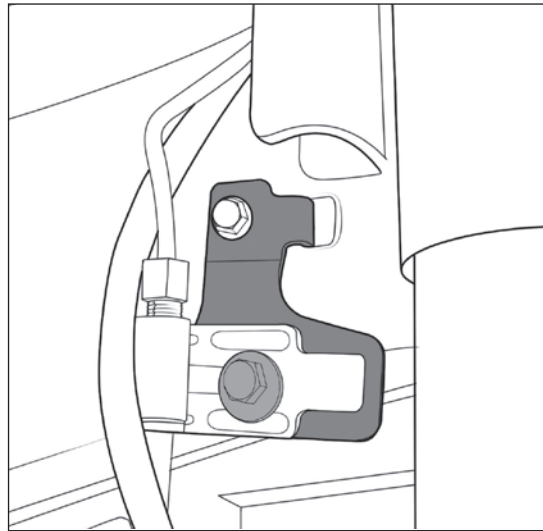

Figure 31

23. For **2011 and newer** models, use supplied zip ties to secure the brake line to the shock as shown. For Remote Reservoir shocks, secure brake line to the spring (Fig. 32).

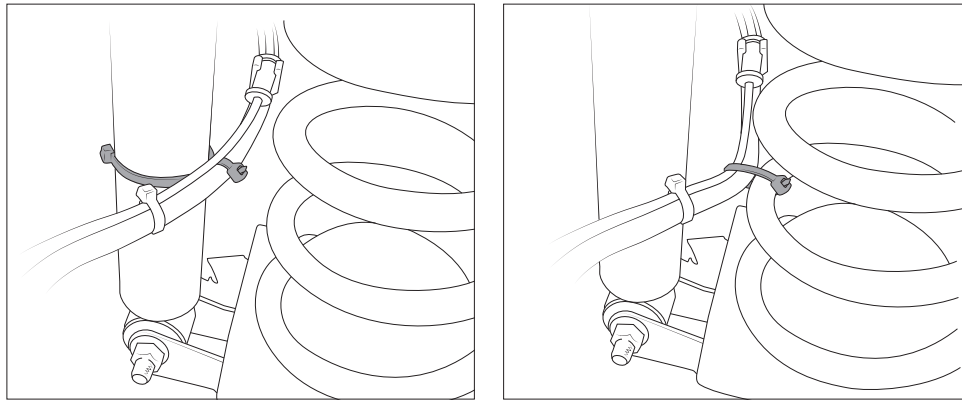

Figure 32

24. Install the automatic transmission skid plate.

For **2011 and newer**, use the 4 supplied spacers, 2 at each side of the skid plate (Fig. 33).

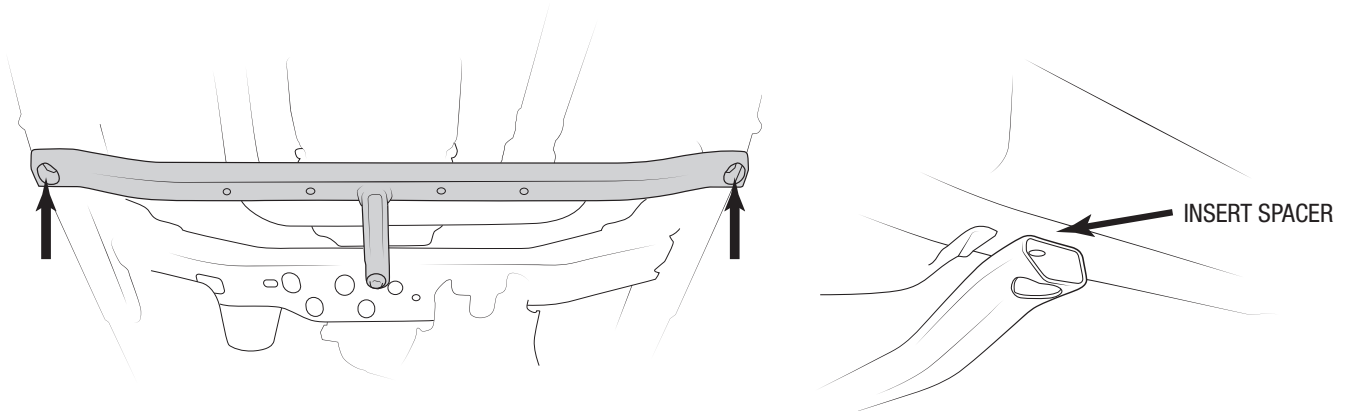

Figure 33



For **2007-2010**

- A. Hold the skid plate in position and mark where the skid plate will need to be trimmed. Trim the skid plate as shown and paint for corrosion protection (Fig. 34).
- B. Install the skid plate using the 4 supplied spacers, 2 at each side (Fig. 34).

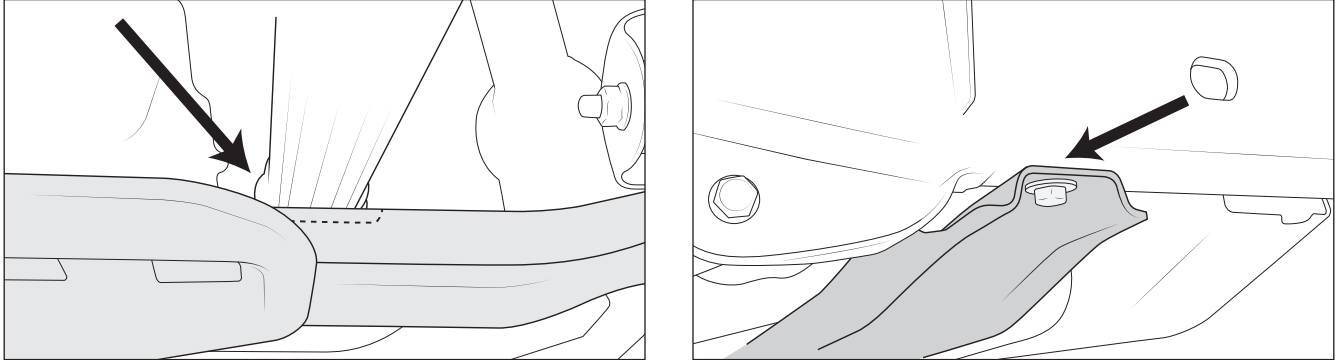

Figure 34

- C. Reinstall wheels and tighten lug nuts, working in a “star pattern.” Place Jeep on level ground. Reconnect the drive shaft making sure to properly align your marks.
- D. Install JK Geometry Correction Front Control Arm Drop Brackets using instructions included in kit.
- E. You may now tighten all fasteners to factory specifications.* Too tight is NOT just right.
- F. Install new Bump Stop Spacers on the rear axle as shown (Fig. 35) using the supplied hardware. DO NOT reverse the orientation from what is shown (screws should be inboard.)

*Refer to Appendix for proper torque specs

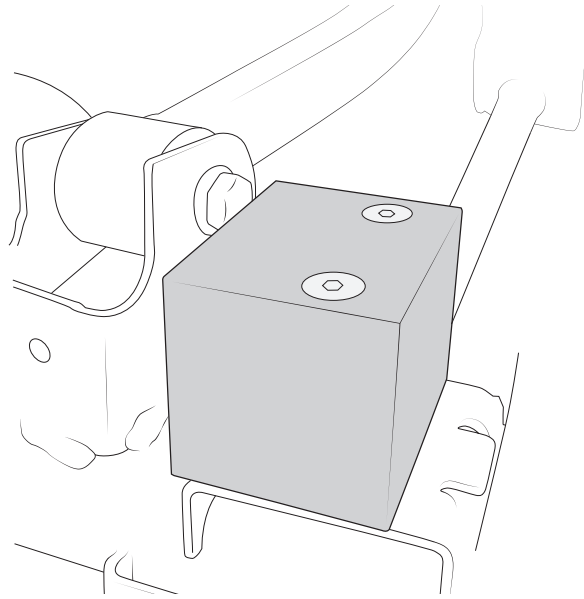

Figure 35

TIP: It is good practice to mark each major bolted suspension connection such as these with a paint pen. Draw a line that runs from bolt head or nut to the adjacent bracket material. This will allow a visual inspection to easily catch bolts that work loose. After approximately 100 miles, you should perform a complete visual inspection and re-torque any suspect bolts as well as your wheel lug nuts.

AEV recommends having a professional alignment done at this point. While your Jeep is on the alignment rack is the correct time to use the AEV ProCal to assist with centering the steering wheel. Please follow the instructions that come with your ProCal.

AEV recommends 28–30 PSI tire pressure with our Suspension Systems.

APPENDIX

JK FACTORY TORQUE SPECIFICATIONS

*nominal torque shown in ft-lbs.

Front Suspension & Steering		
UCA bushings	M12	75
LCA bushings	M14	125
Track bar bushing frame	M14	125
Track bar bushing axle	M14	125
Stabilizer end link top	M12	65
Stabilizer end link bottom	M12	75
Shock Absorber	upper M12 bayonet	20
	lower M12	56
Steering gear		87
P/S pump to engine		21
High pressure hose pump		22
Hoses to steering gear		21
Intermediate shaft, all points	M10	42
Intermediate shaft toe plate		100 in. lbs.
Steering damper	axle M12	50
	cross-link M12	50
Pitman arm to gear	7/8	195
Pitman to drag link nut	M14	78
Drag link to knuckle nut	M14	125
Tie rod to knuckle nut	M14	63
Tie rod clamp	M10	45
Drag link clamp	M10	26

Rear Suspension		
UCA bushings	M14	125
LCA bushings	M14	125
Track bar bushing frame	M14	96
Track bar bushing axle	M14	111
Stabilizer bar sill bushing	M10	45
Stabilizer bar to link	M12	66
Stabilizer bar link to axle	M12	75
Shock Absorber	upper M8	37
	lower M12	56

Cab Mounts		
	M10 short bolts	45
	M12 stud FESM	80

Powertrain Mounts		
	M10 bracket to block	45
	M12 bracket to block	90
	M12 Isolator to frame	85
diesel	bracket to engine	85
diesel	M12 Hydro mt to bracket	65
diesel	M12 Hydro mt to frame	65

Transmission Mount		
	M10 trans to mount	40
	M10 mount to frame	40

Wheels		
(5" bolt circle/1.75" offset)	5 x 1/2" stud	105

Driveline		
T-case companion flange nut		210
Front driveshaft	to front axle	80
	to t-case	22
Rear driveshaft	to rear axle	22
	to t-case	22