



////////////////////////////////////

REAR DIFFERENTIAL COVER RAM 2500/3500 11.5" & 12" AXLE

**Please note that these instructions apply to both RAM Rear Differential Covers.
Please confirm proper vehicle fitment before starting installation.**

2010–2018 2500/3500 Trucks with 11.5" Rear Axle / 2019-2022 Power Wagon: **10404021AA**

2019+ 2500/3500 Trucks with 11.5" & 12" Rear Axle / 2023+ Power Wagon: **10404022AA**

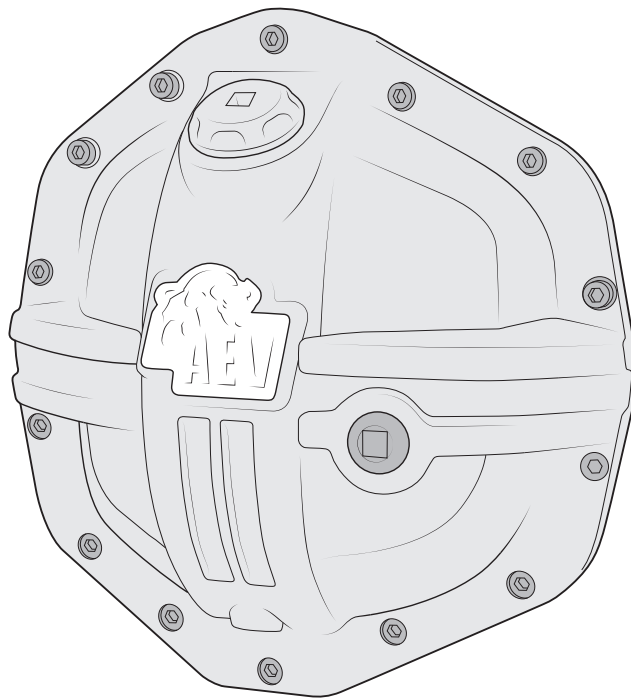



PLEASE READ BEFORE YOU START

TO GUARANTEE A QUALITY INSTALLATION, WE RECOMMEND READING THESE INSTRUCTIONS THOROUGHLY BEFORE BEGINNING ANY WORK. THESE INSTRUCTIONS ASSUME A CERTAIN AMOUNT OF MECHANICAL ABILITY AND ARE NOT WRITTEN NOR INTENDED FOR SOMEONE NOT FAMILIAR WITH AUTO REPAIR.

INCLUDED PARTS	QTY	REQUIRED TOOLS
Differential Cover	1	Common Hand Tools
Drain Plug	1	Torque Wrench
O-Ring	1	Thread Tape
Socket Head Cap Screws	14	Allen Wrenches
Alcohol Swab	1	
AEV Badge	1	

CAUTION

The adhesive properties of the AEV Bison badge is very strong. Once the protective cover is removed from the back side of the badge and it is placed on an object, it will not come off without permanently damaging it and/or the surface it comes in contact with.

CAUTION

The AEV logo badge is resistant to most petroleum based oils, greases and aliphatic solvents and resistant to mild acids, alkalis and salt solutions. However, AEV recommends cleaning the AEV logo badge and surrounding area after any contact with the above mentioned materials immediately. To clean, use warm soapy water and a non-abrasive sponge, rinse with low pressure water. Use of a high pressure sprayer is not recommended in this area closer than 5 feet.

NOTE: Differential Cover 10404021AA will fit 2019-2022 Power Wagon, however minor trimming of the brake line bracket is required.



I. REMOVE FACTORY COVER

1. Place drain pan under differential housing.
2. If equipped remove four bolts that hold sway bar bushings in place. Allow sway bar to rotate out of the way.
3. Remove fill/check plug (fig. 1), **DO NOT discard it will be reused.**
4. Remove all other hardware and discard.
5. Remove cover but **retain gasket it will be reused.**
6. Wait until fluid is done draining and clean mating surface.

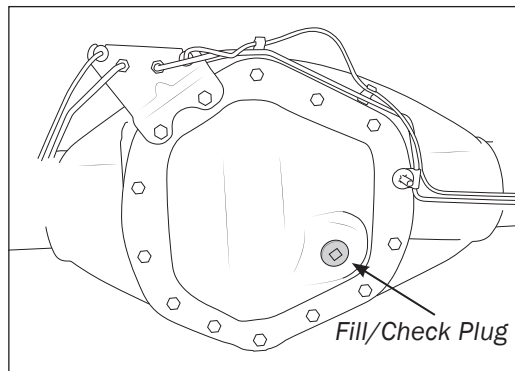

Figure 1

II. INSTALL AEV COVER

1. Install factory gasket and new cover with new hardware provided. NOTE: there are two lengths of screws.
 - A. Two of the longer bolts with washers bolt the brake line bracket to the cover. If you do not have a brake line bracket like the one pictured still use longer bolts and washers in these locations.
NOTE: 2019-2022 Power Wagon has a different brake line bracket. Some trimming will be required on the lower portion of the bracket to properly line up the holes.
 - B. One long bolt with washer goes through the p-clip provided to hold the brake line on the right hand side.

NOTE: All hardware should get a dab of medium strength thread locker

2. Torque all hardware to 25 ft-lbs.

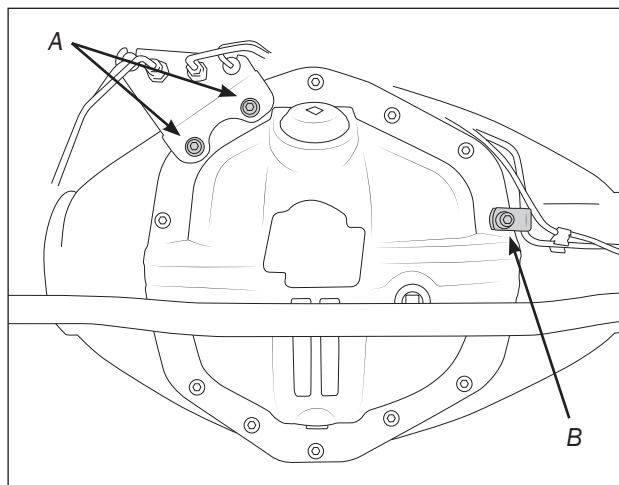

Figure 2



III. INSTALL PLUGS AND FILL

1. Install the black allen-head drain plug into the tapped hole at the bottom of the cover using thread sealer or teflon tape (fig. 3).
2. Fill the differential with 75w 90 synthetic fluid. It will take approximately 3 1/2 quarts of fluid. For proper level of fluid fill until fluid is level with the check hole.
3. Reuse factory fill plug and gasket in check hole (fig. 3). Torque to 25 ft-lbs.
4. Install rubber O-ring on threaded cap and lightly lubricate. Install and torque to 40 ft.-lbs.
5. Clean embossed area for emblem with alcohol swab provided. Install emblem with firm even pressure.

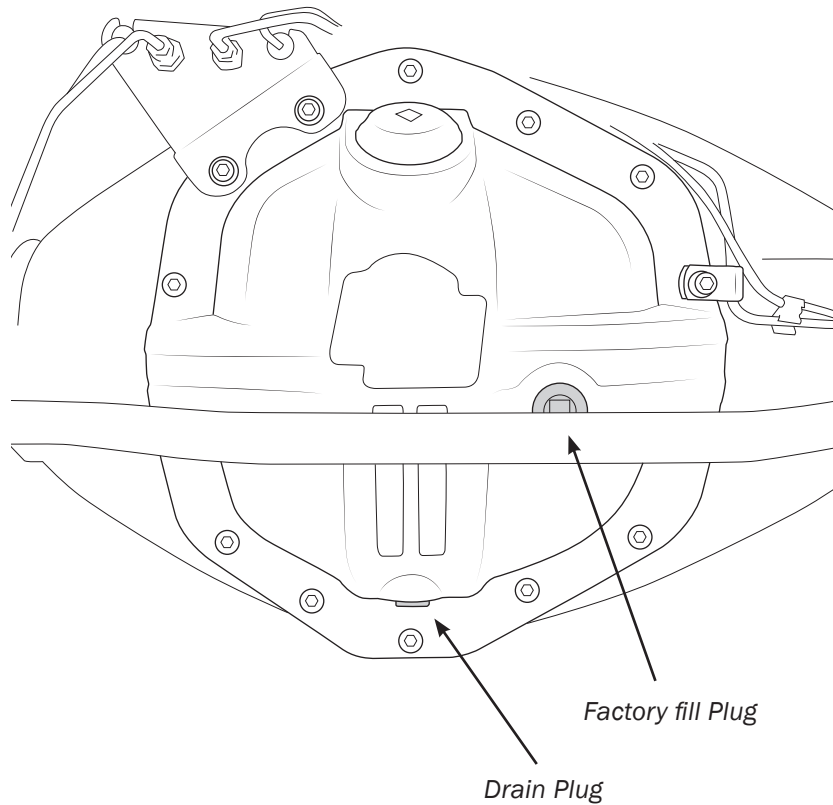

Figure 3