



////////////////////

3" DUALSPORT FRONT SUSPENSION

RAM TRUCK 2500/3500

INCLUDED PARTS	QTY	REQUIRED TOOLS
Coil Spring Mount & Bumpstop Kit - Front	1	Common hand tools
Radius Arm & Track Bar Bracket Kit - Front	1	Quality torque wrench capable of 324 ft-lb
Draglink & Track Bar Kit - Front	1	Bright colored paint marker
Shocks - Front PN: F4-24246002-MO (Gas) F4-24246002-MO (Diesel)	2	Abrasive cutoff wheel or metal saw (trim- ming may be required in step 19-B)
Driveshaft Spacer Kit	1	



PLEASE READ BEFORE YOU START

TO GUARANTEE A QUALITY INSTALLATION, WE RECOMMEND READING THESE INSTRUCTIONS THOROUGHLY BEFORE BEGINNING ANY WORK. THESE INSTRUCTIONS ASSUME A CERTAIN AMOUNT OF MECHANICAL ABILITY AND ARE NOT WRITTEN NOR INTENDED FOR SOMEONE NOT FAMILIAR WITH AUTO REPAIR.

NOTE: This system uses a no-drill top mount drag link that requires an unmodified OEM steering knuckle. If your vehicle currently has a modified knuckle with sleeve inserted from top/previous generation AEV drag link (see illustration), you must order PN 68216188AA OEM knuckle. Failure to do so will result in an unsafe installation and potential steering failure.

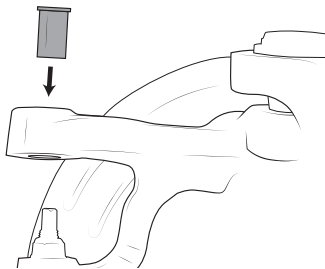

! ATTENTION !

IMPORTANT: IMPROPER NUT TORQUE COULD CAUSE STEERING FAILURE. Proper clamp load is critical on the no-drill draglink to knuckle interface. The nut **MUST** be torqued to 120-130 ft-lb using a torque wrench. Drag link should also be inspected and the nut torque checked after 500 miles and at each oil change. Do not install using an impact gun or a “tight enough” mentality. They must be properly torqued to the specified range using a torque wrench.

NOTE: Installation on a Powerwagon requires the purchase of new Coil Springs, Mopar PN: 68172091AA (front) and 68091216AA (rear).

NOTE: If installing with the factory front bumper, some trimming of the bumper will be necessary.

NOTE: If running smaller than 20” wheels, 6” or less of backspacing is required. Factory 18” wheels will not clear top-mount draglink.



FRONT SUSPENSION 2500/3500

A. FRONT SUSPENSION PREPARATION

NOTE: SAVE ALL HARDWARE UNTIL INSTALLATION IS COMPLETE.

1. Support the vehicle by the frame until the front wheels are off the ground.
2. Remove the front wheels and tires.
3. Remove the drag link.
 - a. Measure from center of pitman arm tie rod stud to center of passenger side knuckle stud. Record the length for reference when setting new draglink length.

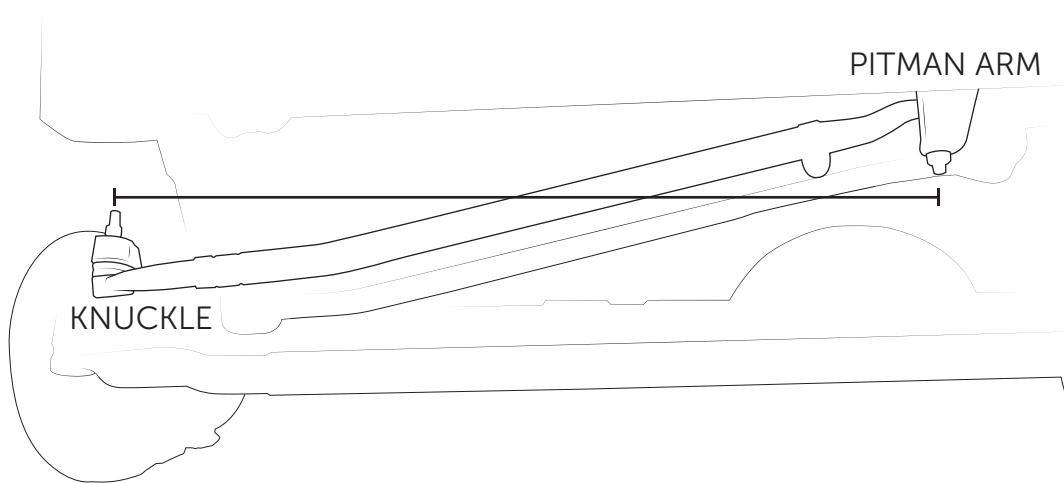

- b. Loosen both jam nuts.
- c. Remove the drag link at the axle end.
- d. Thread adjuster sleeve out until separated from drag link and pitman arm tie rod (fig. 1).

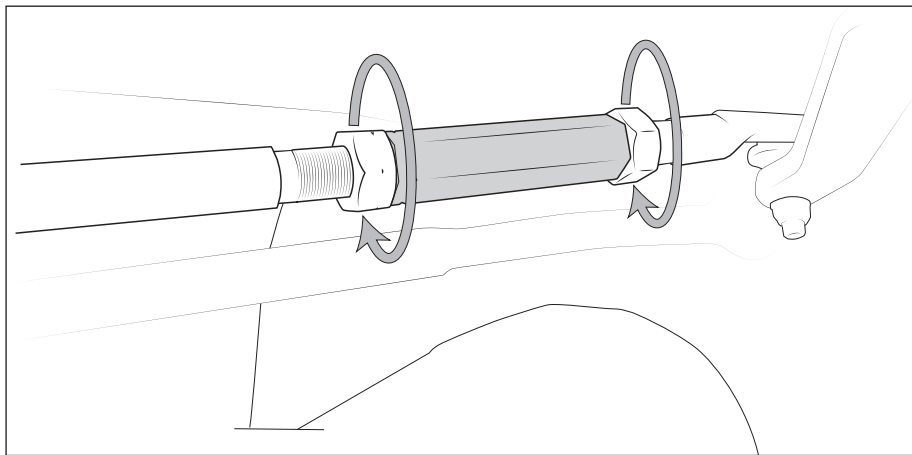

Figure 1

- e. Remove jam nut off of the pitman arm tie rod end. This will not be re-used. Jam nut on draglink end can be discarded along with original draglink..



4. Remove the track bar and save the hardware.
5. Remove the sway bar links at the axle end only.
6. Remove the steering damper bolt at the axle. Leave attached at the tie rod.
7. Remove the front brake lines.
 - a. Clamp off the flexible brake lines (fig. 2).
 - b. Remove the steel brake lines between the two flexible lines (fig. 3).
 - c. Remove the flexible line brackets at the top of the radius arms and let hang (fig. 4).

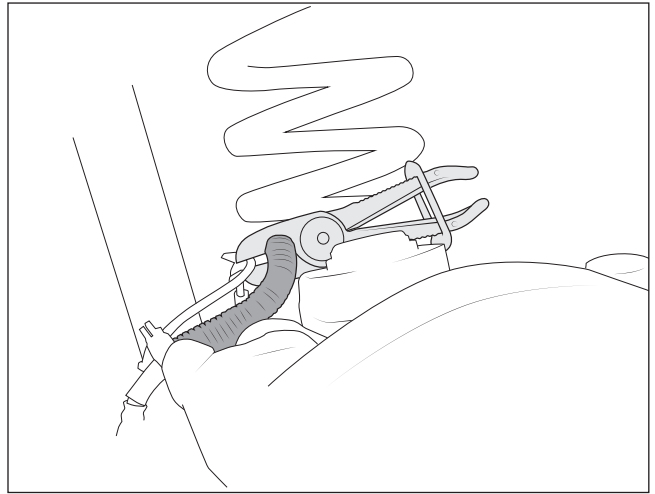
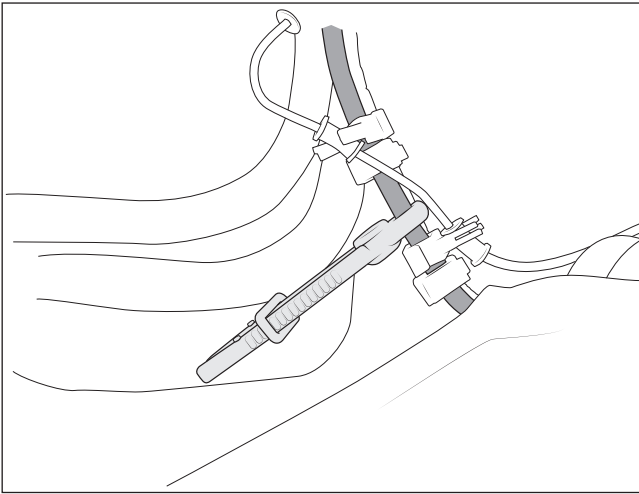

Figure 2

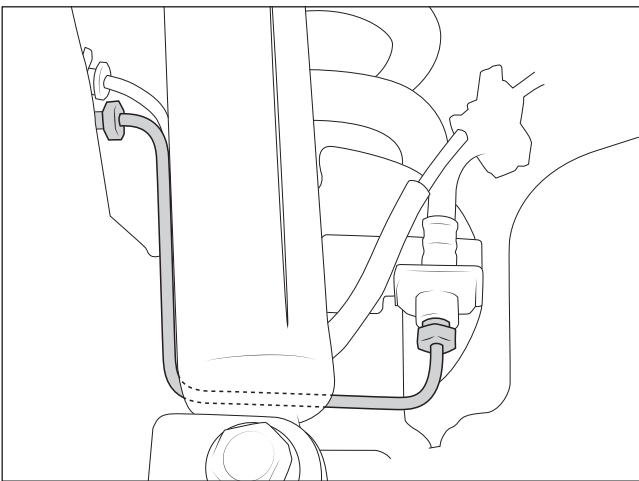

Figure 3

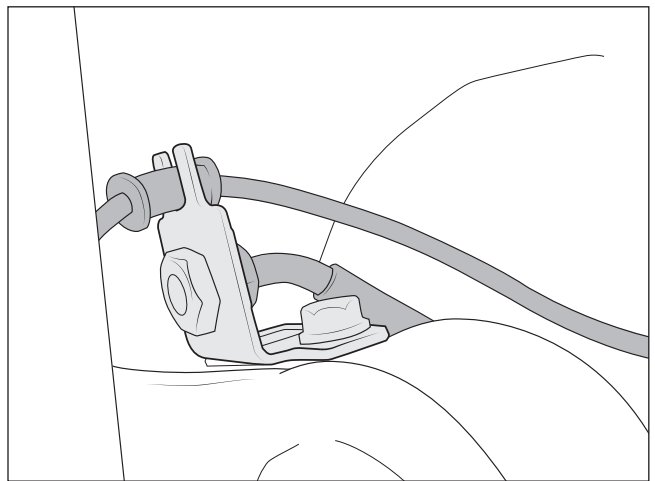

Figure 4



8. Unplug the central axle disconnect and remove the zip tie (fig. 5).
9. POWER WAGON ONLY – Disconnect the front locker plug and remove the zip tie from the axle (fig. 6).

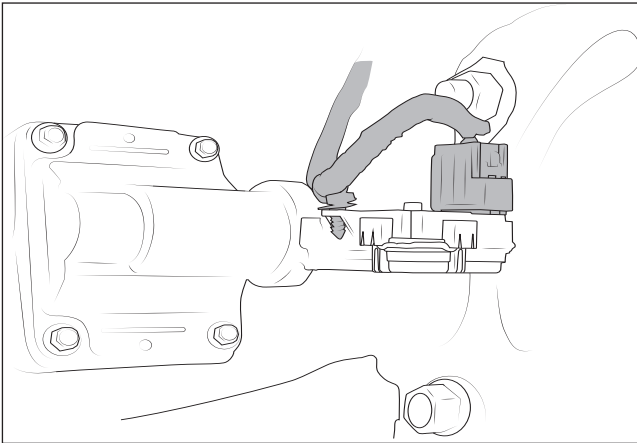

Figure 5

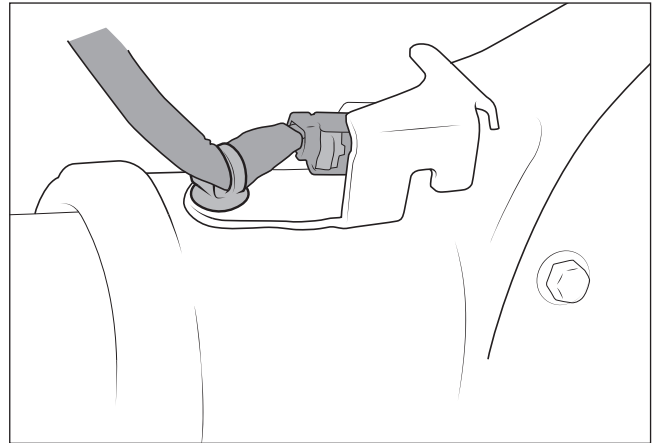

Figure 6

10. Remove the axle vent from the brake line bracket and shock tower (fig. 7).

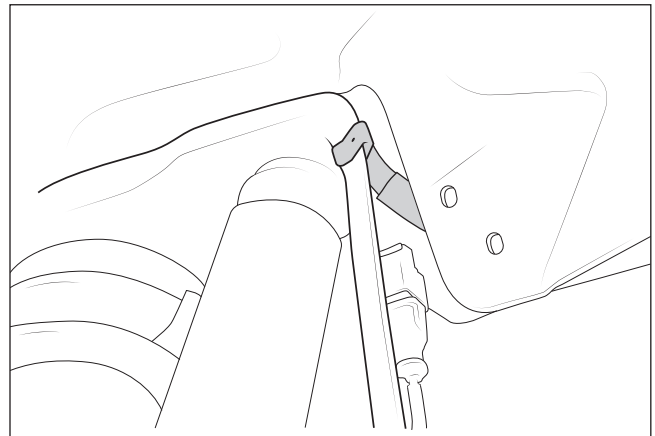
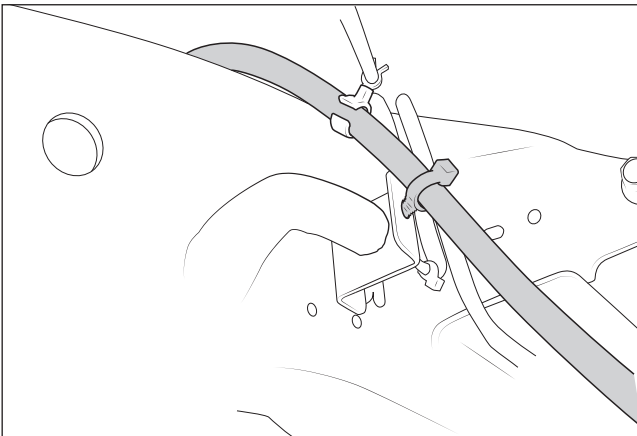

Figure 7

11. Disconnect the front drive shaft at the axle end. **Make sure to mark both sides of the connection so you can properly align it when you reconnect it.** Tie loose end of the drive shaft up so it will not hang down. **Failure to follow this step may result in damage to your drive shaft.**
12. Support the front axle and remove the shocks.
13. Lower the front axle enough to remove the front coil springs. Check to make sure the brake lines are not catching on anything.
14. Remove the lower coil spring isolators from the axle.



15. Using the AEV right side coil spring mount (NRM51000AB) as a template, mark and trim the factory coil bucket as shown (fig. 8). Paint bare metal for corrosion protection.

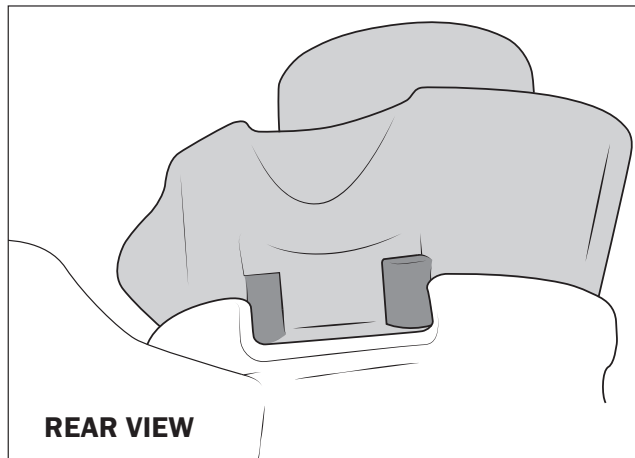

Figure 8-A: Center Coil Spring mount in Bucket Using Rear Tab

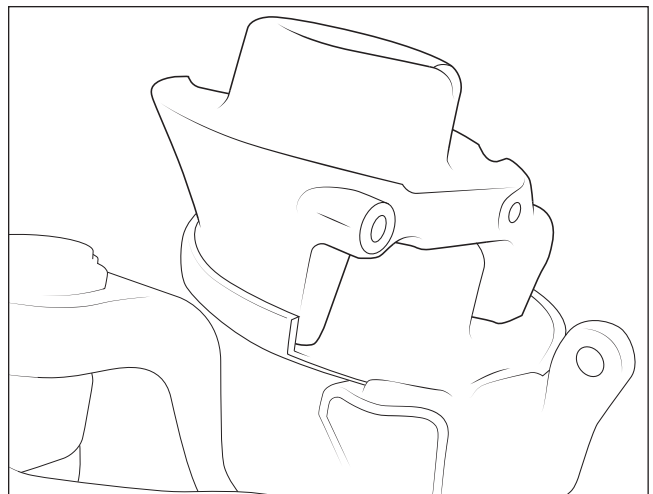
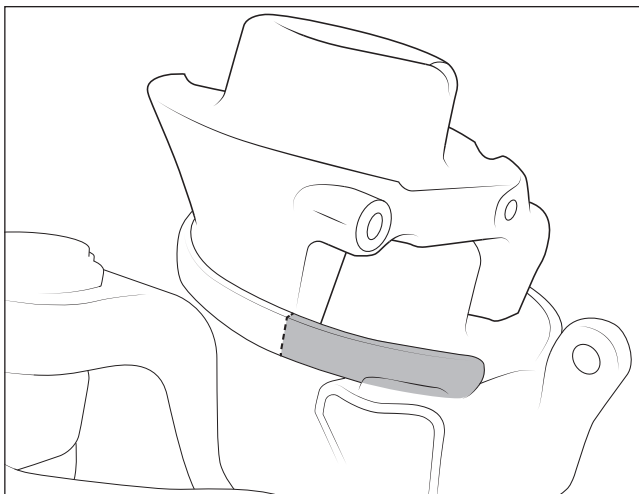

Figure 8-B: Remove Shaded Portion



B. FRONT SUSPENSION INSTALLATION

1. Install the radius arm relocation brackets using hardware bag #1.
 - a. Preassemble the AEV radius arm brackets for installation (Fig. 9). Note the additional spacer for 40" tire applications.

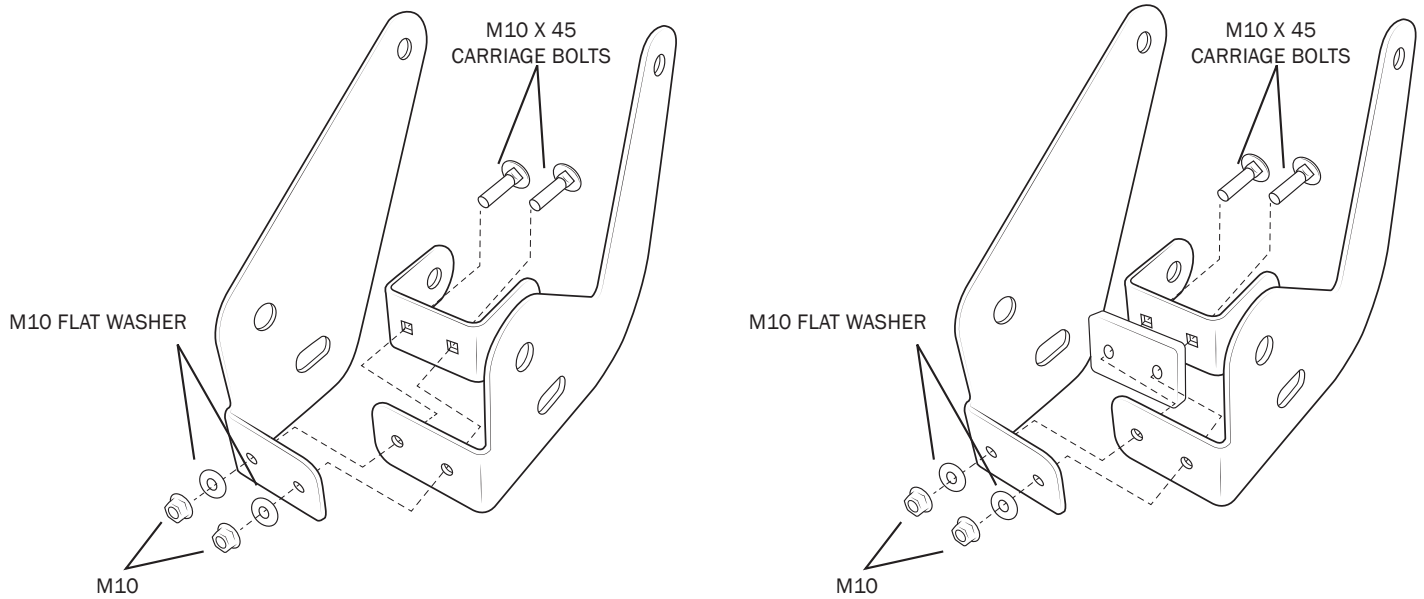

Figure 9 Left: 37" Tires Right: 40" tires

- b. With the front axle still supported, remove one radius arm bolt at the frame.
 - c. Lower the radius arm enough to put the radius arm brackets and spacer in place.
 - d. Install the supplied spacers on each side of the frame rail as shown (fig. 10).

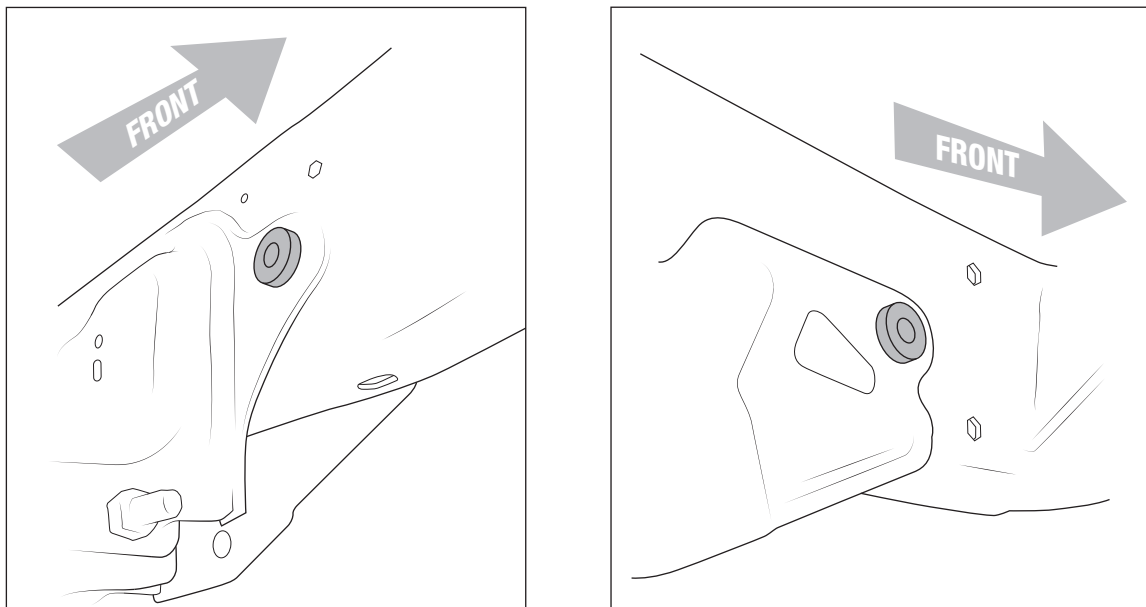

Figure 10 – Left: Inside Right: Outside



- e. Install the brackets to the frame with the supplied hardware (leave loose at this time) (fig. 11).
NOTE: The M18 X 130 bolts MUST go in the original radius arm hole. The M18 X 140 will interfere with the cross member.

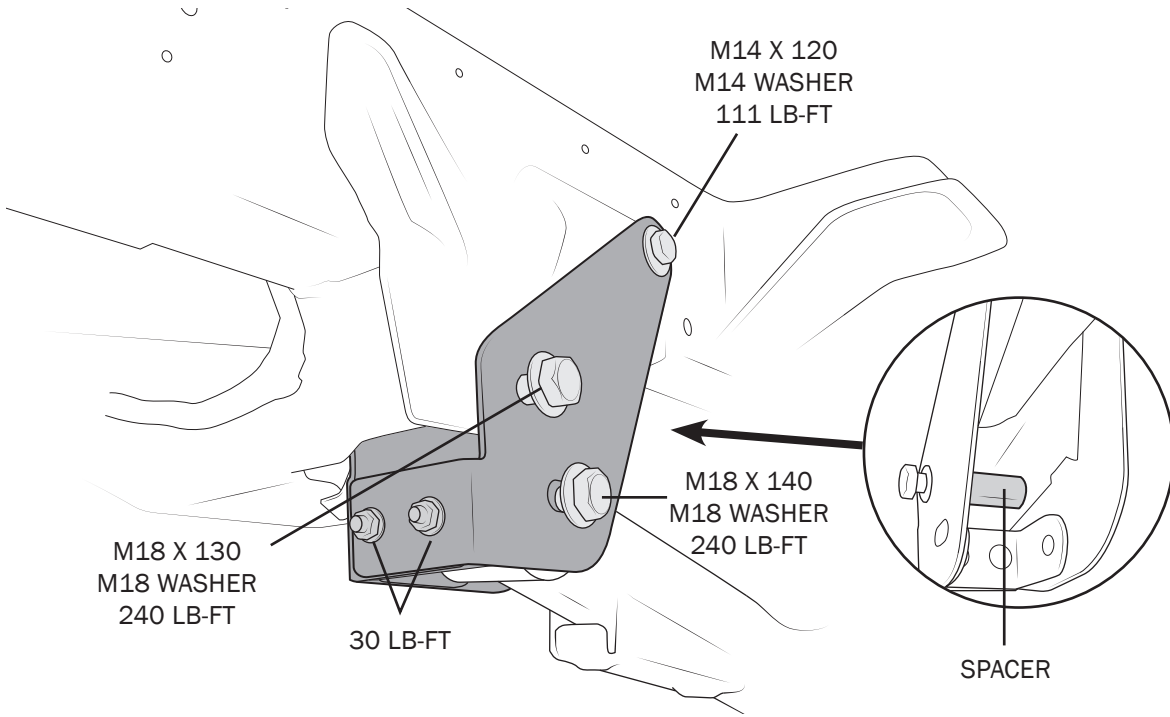

Figure 11-A

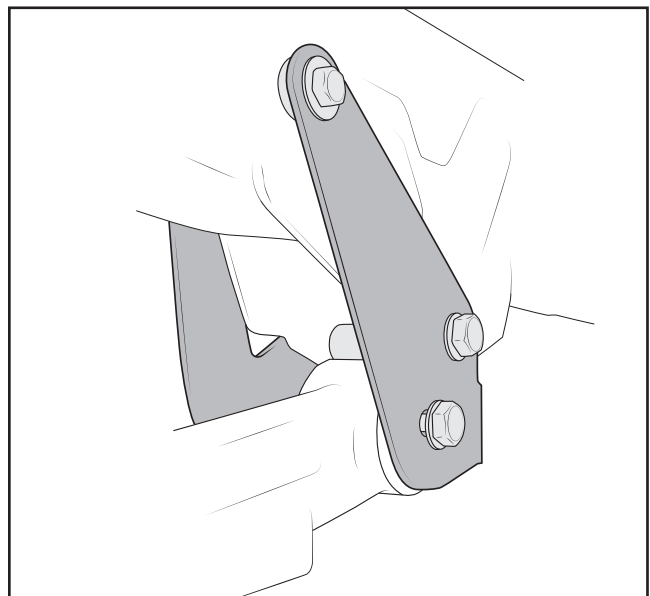
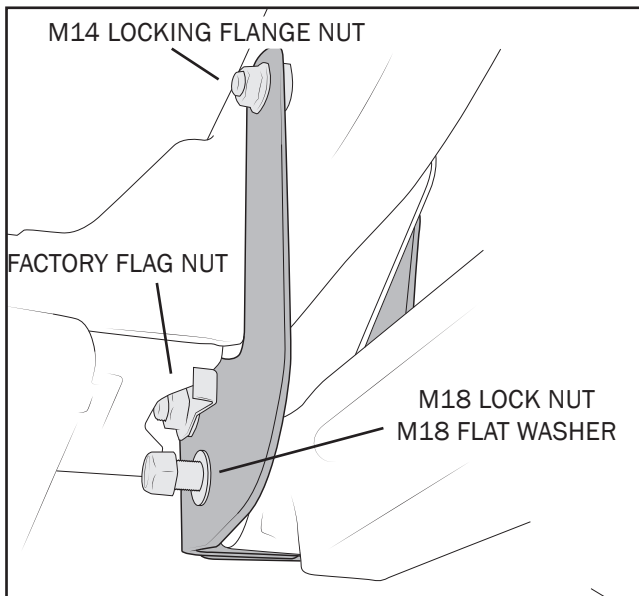

Figure 11-B



- f. Insert the M18 X 140 bolt through the radius arm.
- g. Repeat the process on the other side.
- h. Tighten and torque all hardware except the radius arm bushing through bolts (These will be tightened later at ride height). Refer to figures 11-A and 11-B for torque specifications.

NOTE for 3500 Trucks with the AISIN AS66RC Transmission upgrade: The chassis wiring harness will contact the front drive shaft at full extension (fig. 12) and must be relocated. Disconnect the wiring harness from the frame so it can be moved further to the rear of the vehicle. Zip-tie in place using existing holes in the frame.

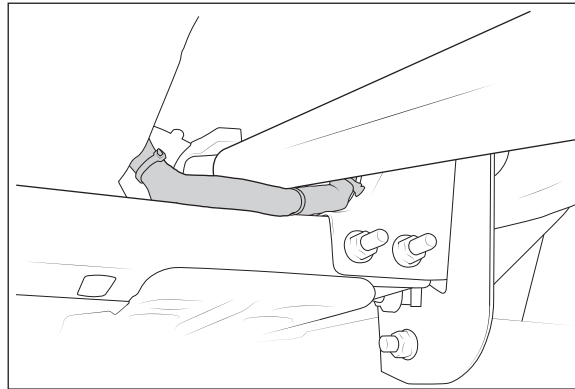

Figure 12

- 2. Install the sway bar relocation brackets using hardware bag #3 (fig. 13).
 - a. Remove one side of the sway bar at the frame and loosen the other side.
 - b. Install one side at a time and torque all fasteners (fig. 13).

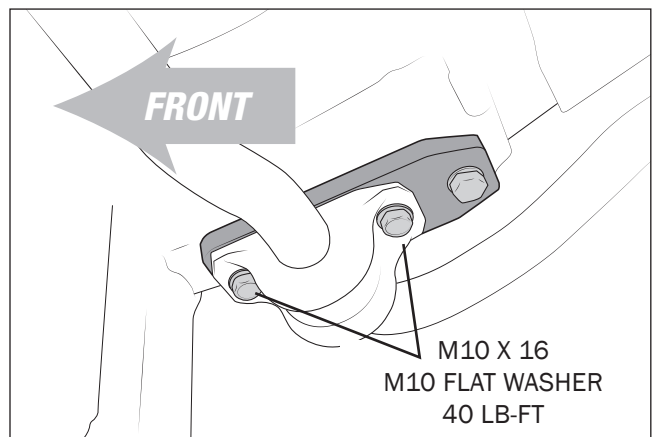
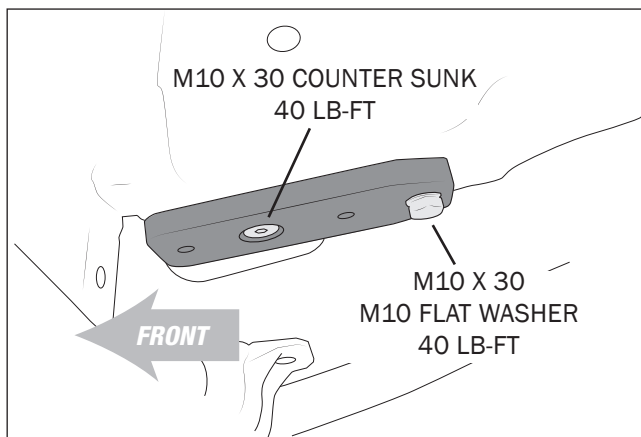

Figure 13

- 3. Remove any debris in the factory coil bucket.
- 4. Install AEV coil spring mounts to the axle using hardware bag #2. Leave loose at this time (fig. 14).

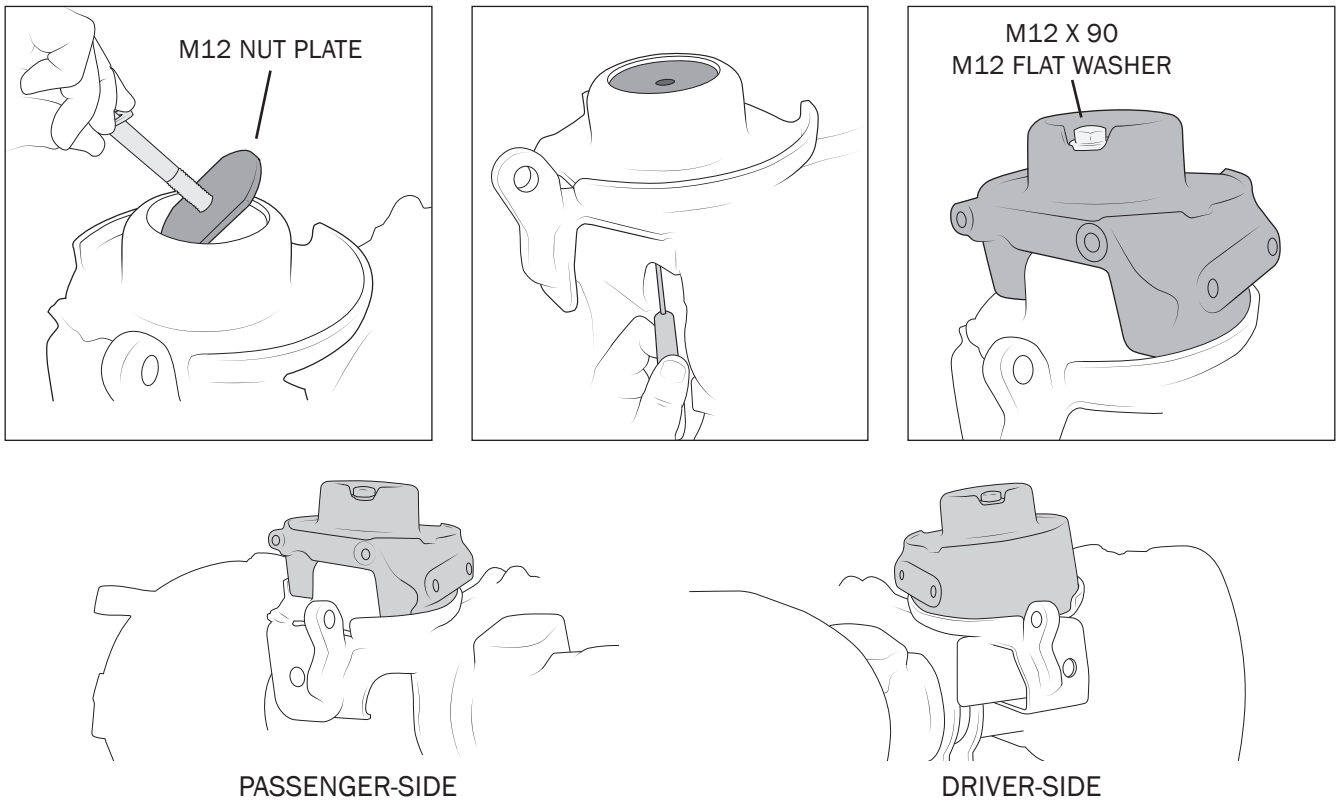

Figure 14

5. Install the track bar relocation brackets using hardware bag #4.
 - a. Remove the two upper bolts from the steering dampener bracket at the axle (fig. 15).

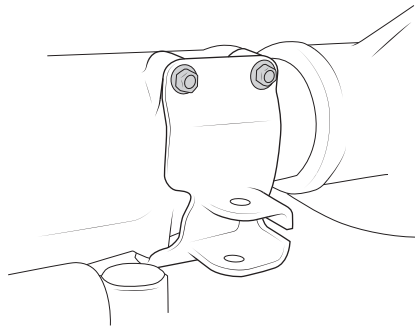

Figure 15

- b. Install the rearward track bar bracket to the new coil spring mount and axle using the supplied hardware. Leave loose at this time (fig. 16). NOTE: snug the M10 x 25 button head bolts as far as possible while still allowing for movement.

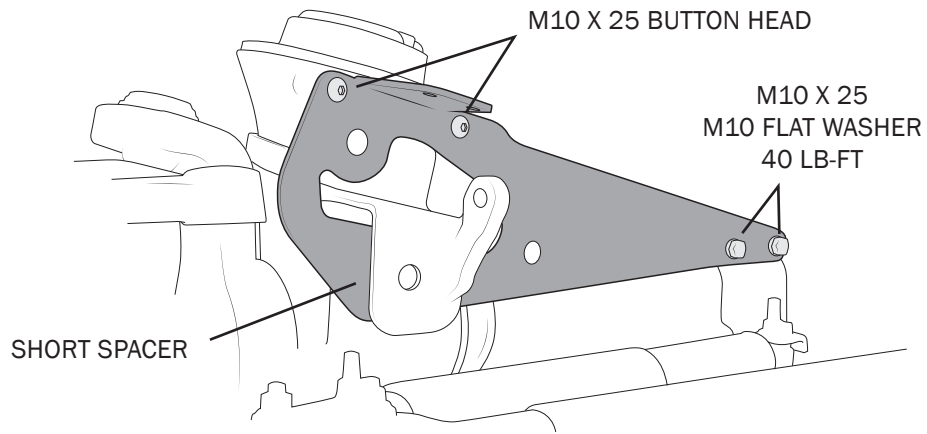

Figure 16

- c. The tab nut off of the frame side track bar bolt will be used for the axle side track bar bolt. The edge will need beveled to fit. Hold it up to the hole and check for clearance and bevel as needed (fig. 17).

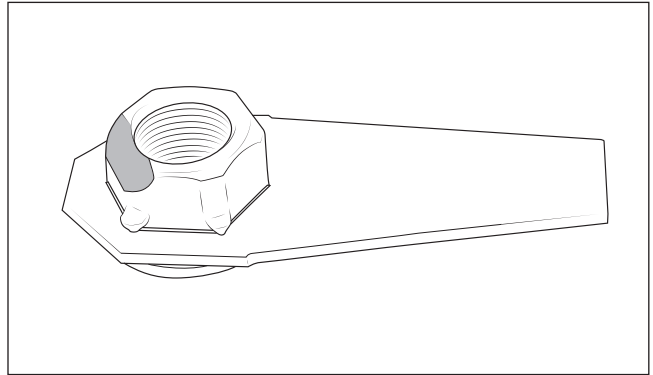
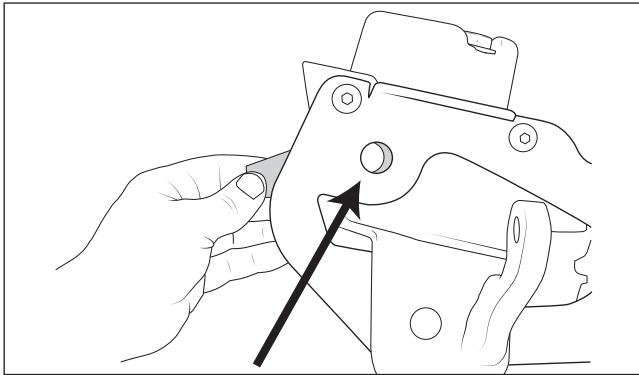

Figure 17

- d. Position the forward track bar bracket and insert the sway bar links back in the factory location and torque to **110 lb-ft** before installing any hardware (fig. 18).

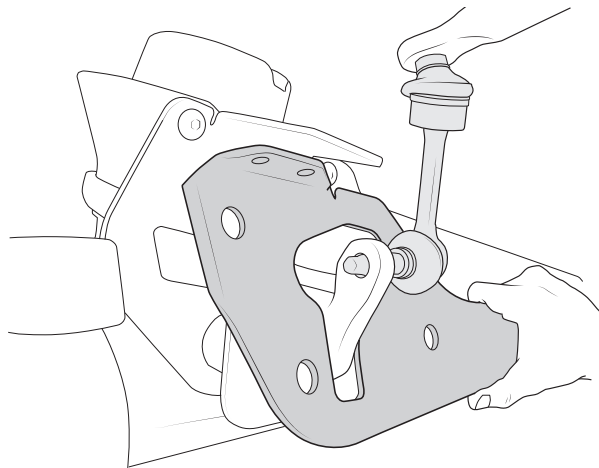

Figure 18



- e. Install the supplied hardware, factory hardware, and spacers into forward track bar bracket. Leave loose at this time (fig. 19).

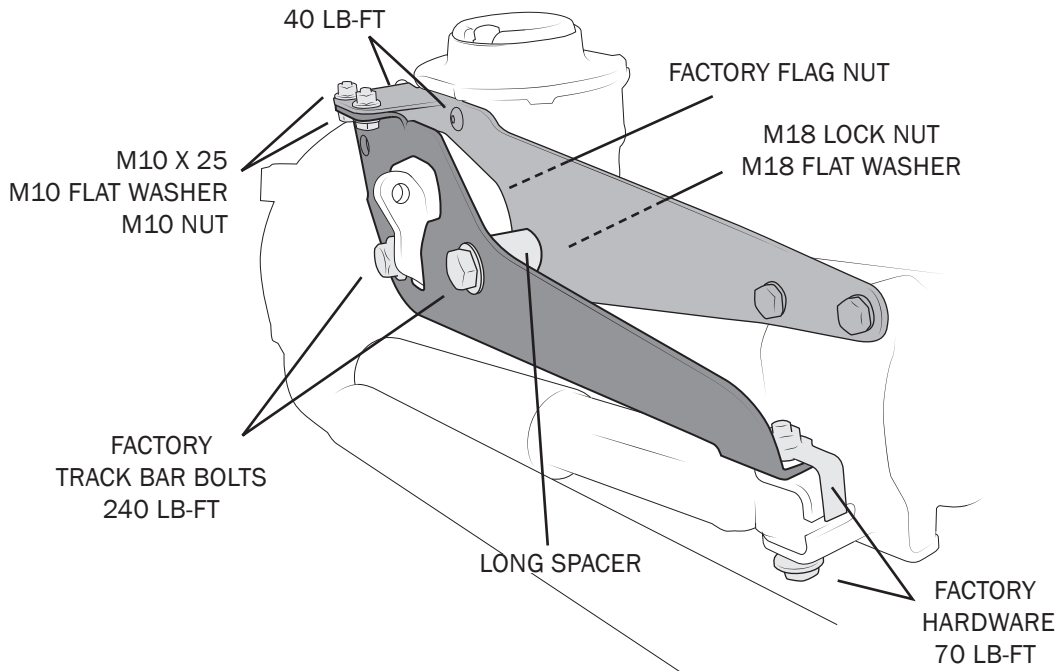
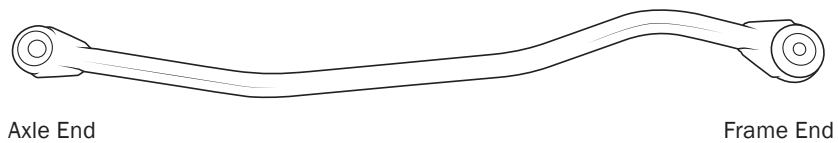

Figure 19 (sway bar link removed for clarity)

- 6. Installing the AEV track bar.



- a. **POWER WAGON ONLY** Other models skip to step 6b - Modify the track bar bracket as shown (fig. 20). Measure 3/4" up to mark the center, then drill a 3/4" hole. Remove remaining material.

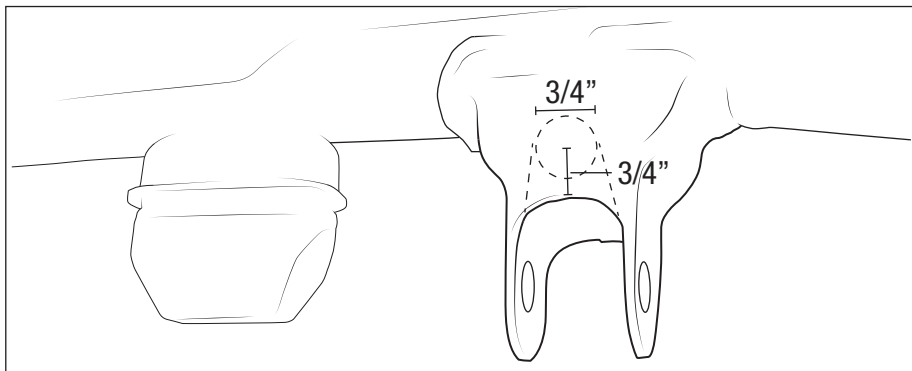

Figure 20



- b. Install the supplied M18 X 70 bolt and washer at axle using the factory frame-side tab nut (leave loose at this time).
 - c. Install the supplied M18 X 80 bolt, washer, and locking flange nut on the frame side, **passing through from the rear of the vehicle to the front. NOTE: If installed backward the bolt can interfere with the axle during suspension movement.**
 - d. Torque all hardware at this time (fig. 18) **EXCEPT: Coil Spring mount hold down bolts and frame-side track bar bolt.**
7. Install the brake line/bump stop brackets and the bump stops.
- a. Pre-assemble the brake line/bump stop brackets to the bump stops as shown (fig. 21). Only snug bolts at this time, you will need movement to adjust position on vehicle.

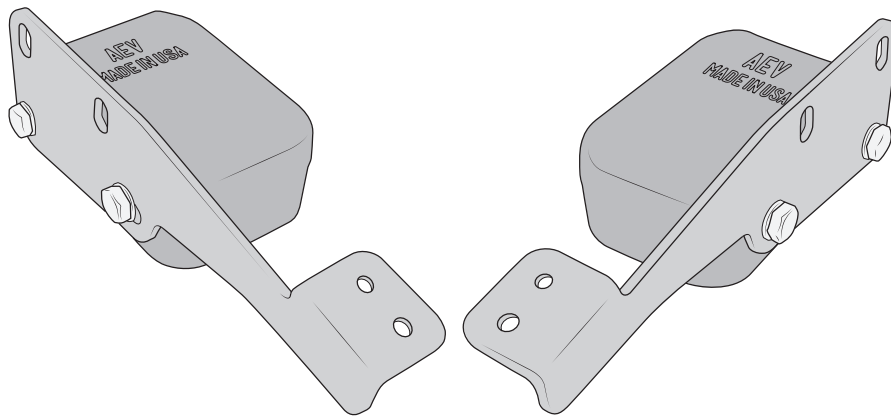

Figure 21

- b. Place the bump stop/bracket assemblies on the axle and start the bolts into the coil spring mounts. Secure with M10 X 25 bolts and M10 Washers but DO NOT tighten (fig. 22).
NOTE: Due to some variations in axles modification of the driver-side coil bucket MAY be required. If the coil bucket is making contact with the brake line bracket and not allowing for proper seating, then it is necessary to remove that portion of the coil bucket (fig. 23).

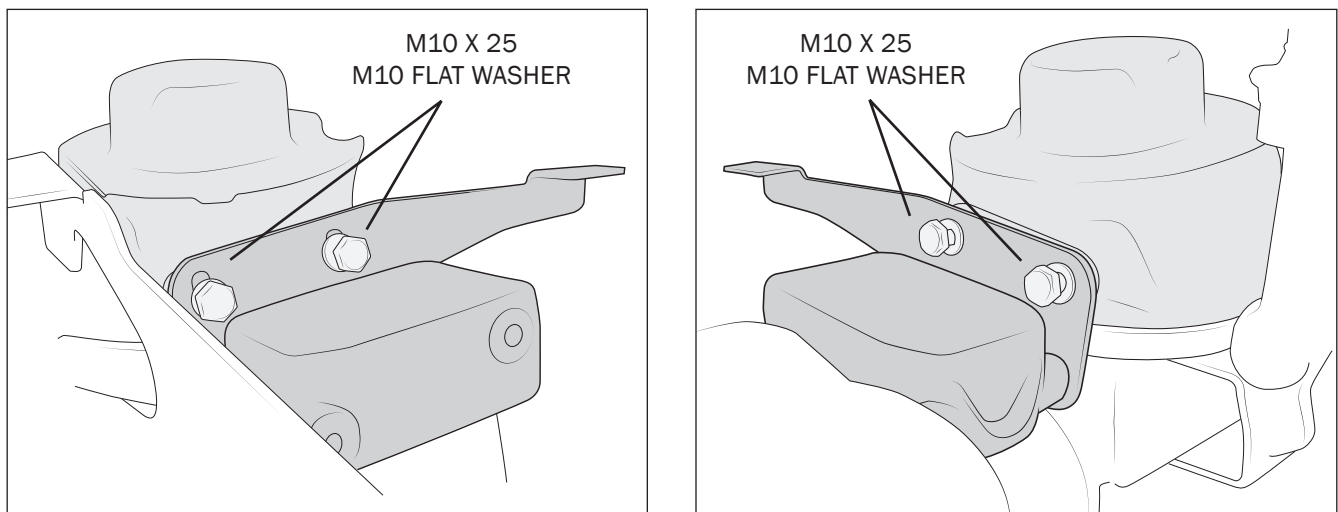

Figure 22

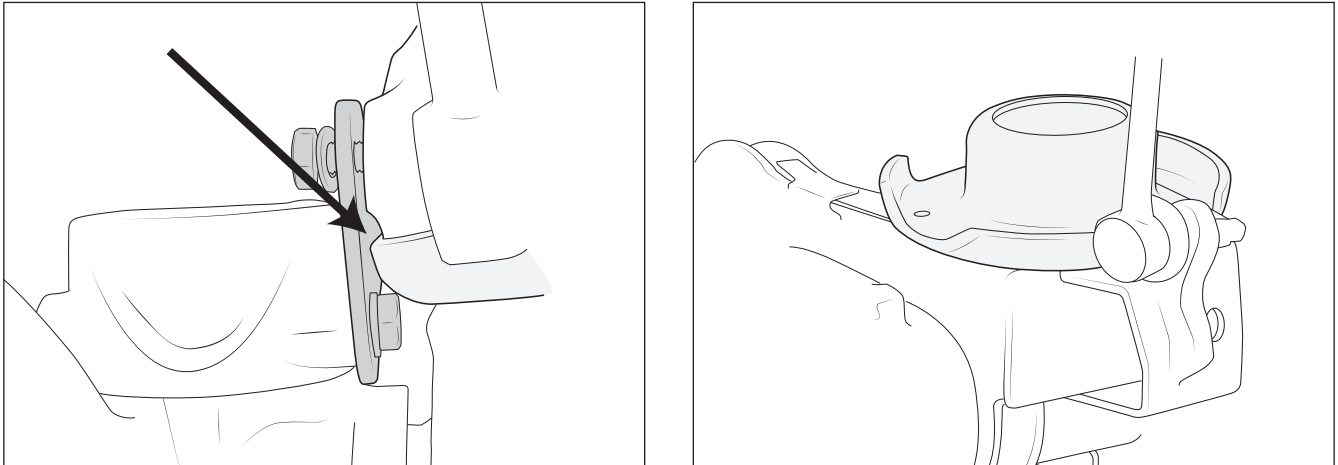

Figure 23: Trim driver-side coil bucket IF NECESSARY

- c. Rotate the coil spring mount to make the mating surface of the bracket parallel to the coil spring mount.
- d. Snug one bracket to bump stop bolt one each side making sure bump stops are seated properly.
- e. Remove the bump stop/bracket assemblies and torque BOTH bolts to **40 lb-ft** Return assemblies to the axle once tight.
- f. Start the rearward bolt into the coil spring mount.
- g. There may be a gap between the bumps top and coil spring mount. Use the supplied shims to shim as shown (fig. 24).
- h. Start the other bolt through the shim.
- i. Tighten both coil spring mount to the axle. NOTE: Only snug these by hand, overtightening will deform the nut plate.
- j. Torque the bump stop/bracket assemblies to the coil spring mounts to **40 lb-ft**
- k. Repeat shimming process on other side.

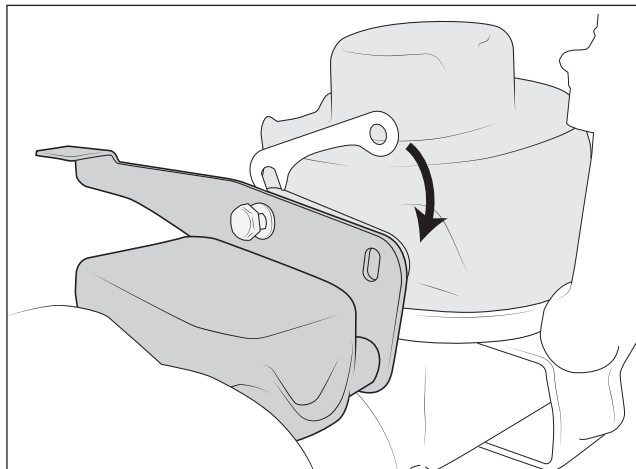

Figure 24



8. Install the factory coil spring isolators to the AEV coil spring mounts (fig. 25).
9. Install the factory coil springs.

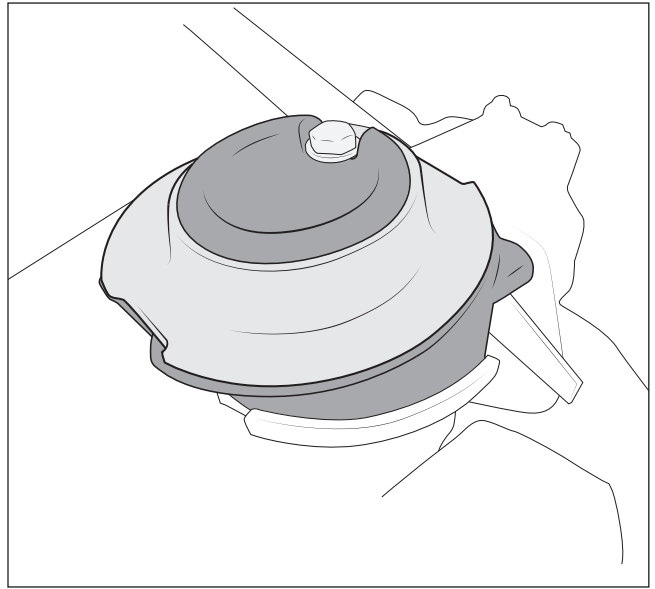
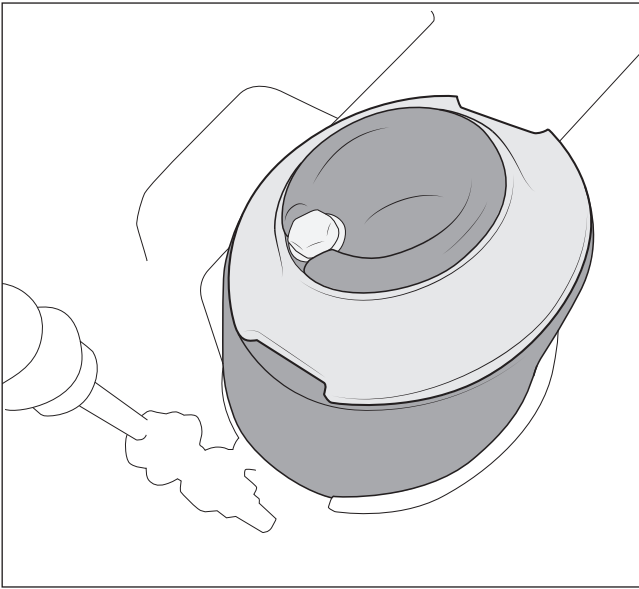

Figure 25

10. Assemble the shock bushings as shown (fig. 26) then install AEV shocks.
Torque the lower bolt to **89 lb-ft**

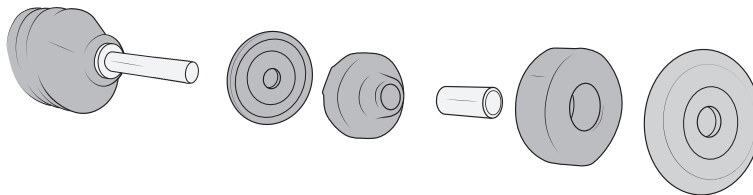

Figure 26

11. Install AEV drive shaft spacer and drive shaft to axle using supplied hardware (fig. 27). Be sure to align using the markings from disassembly. Use blue thread locker and torque to **85 lb-ft**

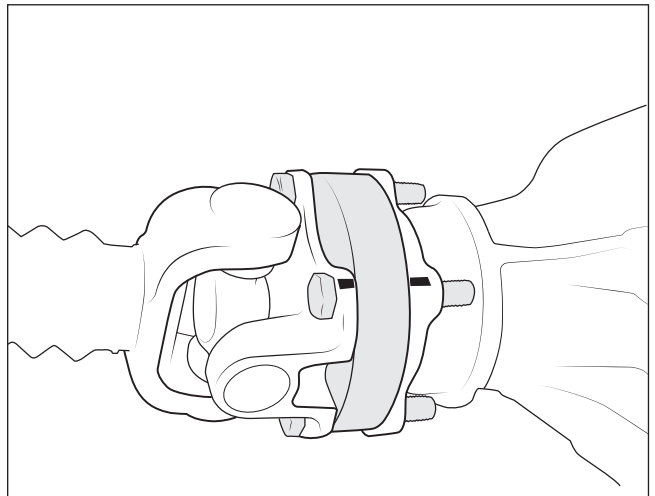
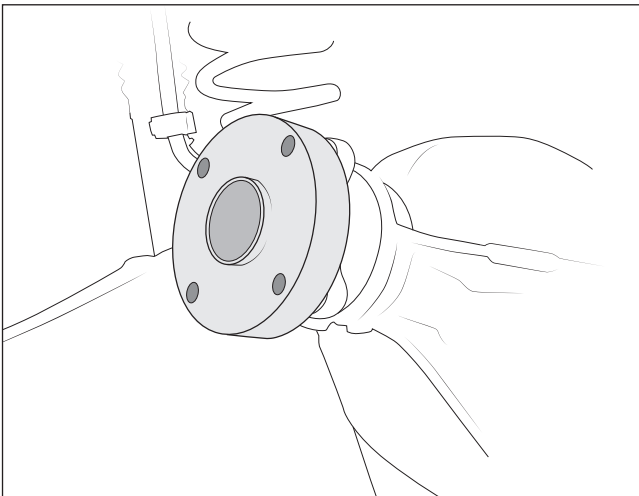

Figure 27



12. Trim the factory soft brake line bracket as shown (fig. 28).
13. Attach the factory soft brake line bracket to the AEV brake line bracket. Use the supplied P-clip to secure the wheel speed sensor wire to the brackets (fig. 29).

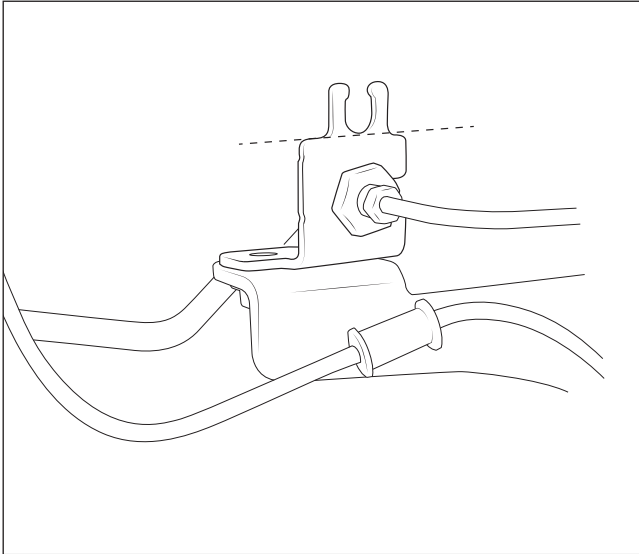

Figure 28

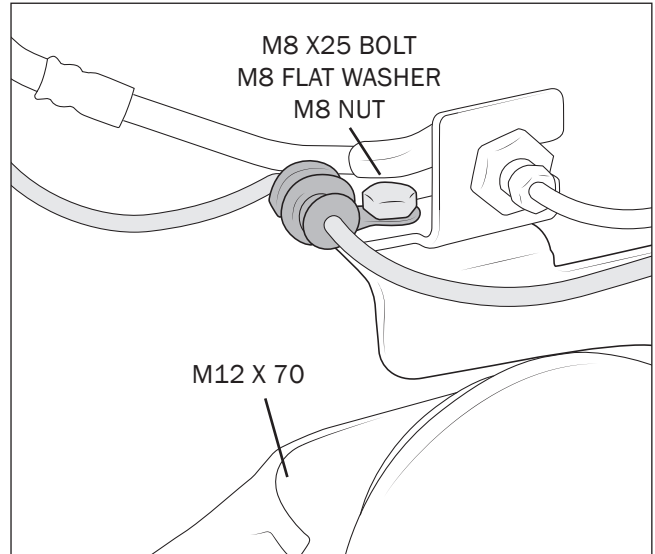

Figure 29

14. Install AEV steel brake lines between the factory flexible lines (fig. 30). **NOTE: On POWER WAGON, slight bending of the brake lines may be necessary for proper drive shaft clearance.**

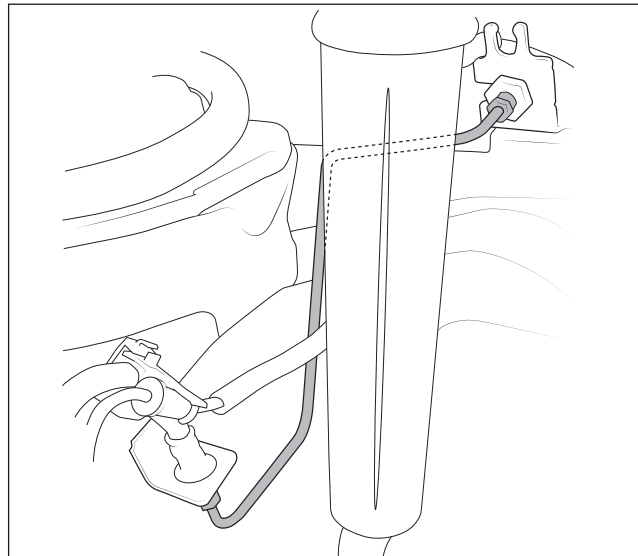

Figure 30

15. Plug the central axle disconnect back in.
16. POWER WAGON ONLY – Plug locker wiring back into axle.
17. Reattach the central axle disconnect and wheel speed sensor wire with zip ties as shown (fig. 31).

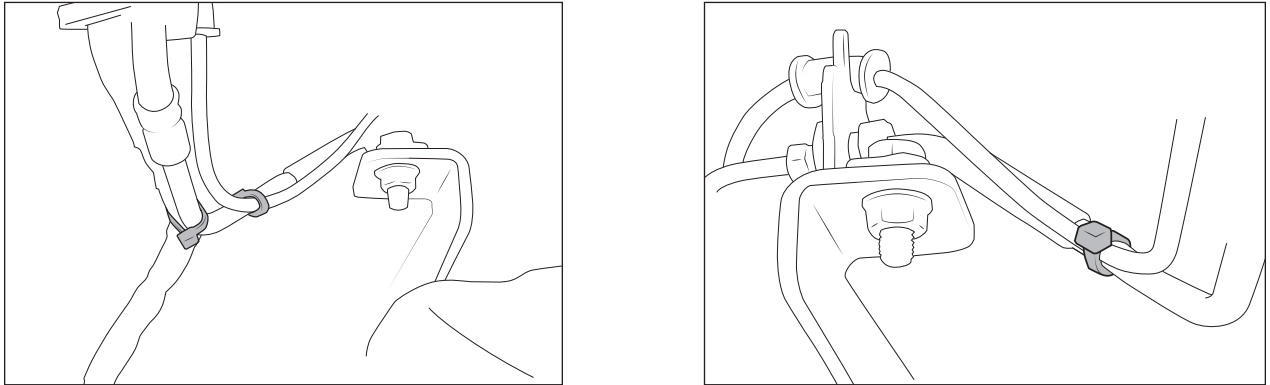

Figure 31

18. Reattach the axle vent hose. Pull slack out of the hose and secure with zip ties as shown (fig. 32).

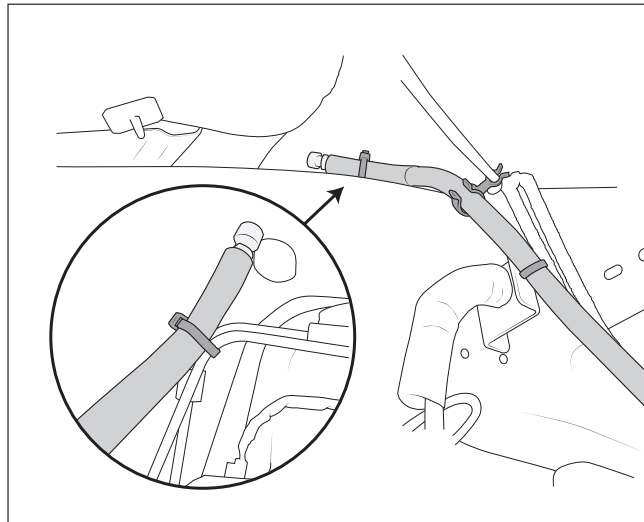

Figure 32



19. Install the draglink.

! ATTENTION !

IMPORTANT: IMPROPER NUT TORQUE COULD CAUSE STEERING FAILURE. Proper clamp load is critical on the no-drill draglink to knuckle interface. The nut MUST be torqued to 120-130 ft-lb using a torque wrench. Drag link should also be inspected and the nut torque checked after 500 miles and at each oil change. Do not install using an impact gun or a “tight enough” mentality. They must be properly torqued to the specified range using a torque wrench.

- a. Thread the new adjuster 6 turns (approx, 3/8”) onto the pitman arm tie rod end before starting threads on draglink (fig. 33)

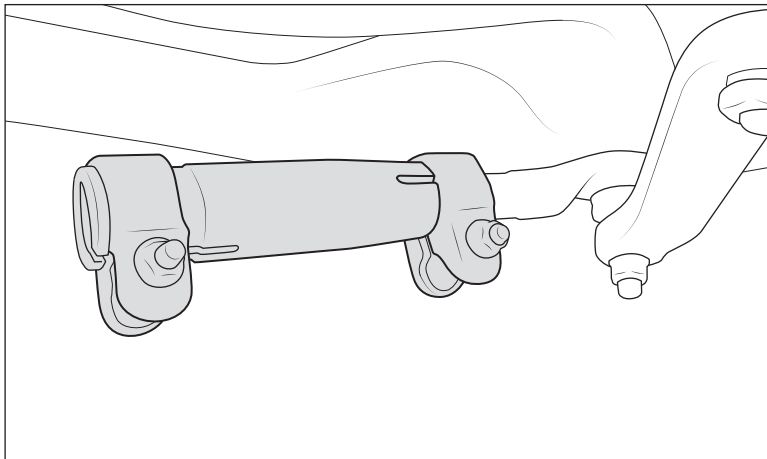

Figure 33

- b. Begin threading draglink end into adjuster. Rotate adjuster until length is close to measurement recorded during disassembly (step 3a). In isolated cases, the OEM pitman arm tie rod end may need to be trimmed slightly to allow draglink assembly to be adjusted short enough. If unable to reach length recorded in step 3a, remove adjuster from OEM pitman arm TRE and trim off clocking feature and 1/4” of thread from the end, being careful not to damage the threads (fig. 34). Clean up the end of the threads, make sure adjuster threads on freely, and then apply paint or anti-rust coating to the trimmed end. Reinstall draglink and adjuster and adjust to length from step 3a.

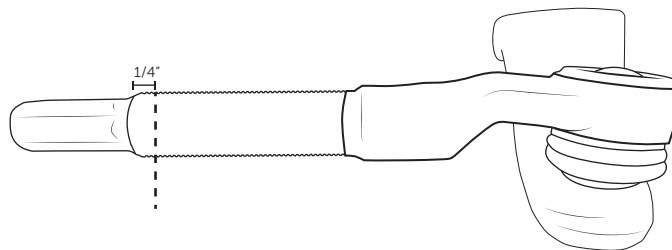

Figure 34



- c. Install new draglink into knuckle. Install tapered insert from bottom side of knuckle and secure with provided nut. Torque nut to **120-130 ft-lb.** (fig. 35).

! ATTENTION !

IMPORTANT: IMPROPER NUT TORQUE COULD CAUSE STEERING FAILURE. Proper clamp load is critical on the no-drill draglink to knuckle interface. The nut **MUST** be torqued to 120-130 ft-lb using a torque wrench. Drag link should also be inspected and the nut torque checked after 500 miles and at each oil change. Do not install using an impact gun or a “tight enough” mentality. They must be properly torqued to the specified range using a torque wrench.

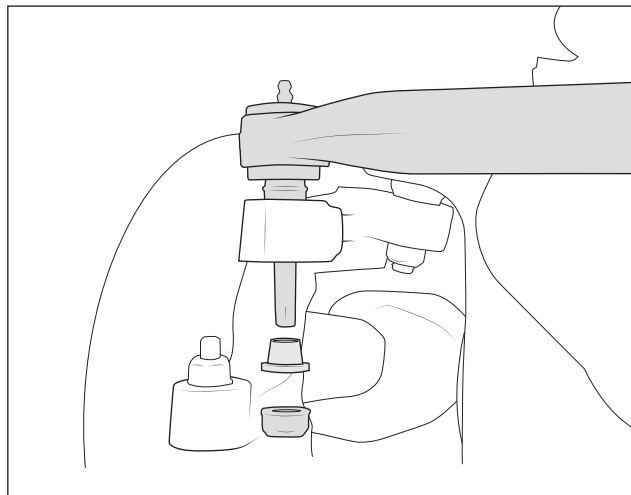

Figure 35

- d. Re-check length measurement and adjust as needed. **Make sure tie rod end at pitman arm is clocked parallel to pitman arm surface. Not doing so will cause bind and potential damage during steering and suspension movement** (fig. 36). Tighten both adjuster clamps to **40 ft-lbs** (fig. 37).

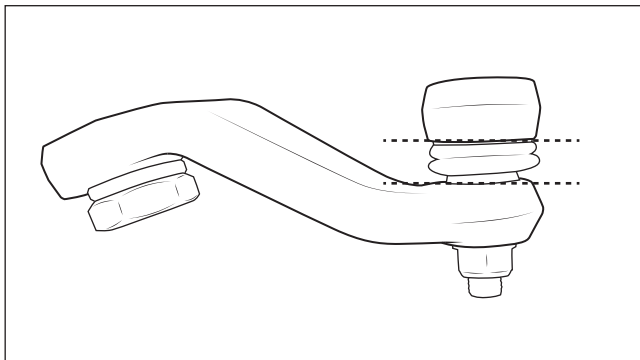

Figure 36

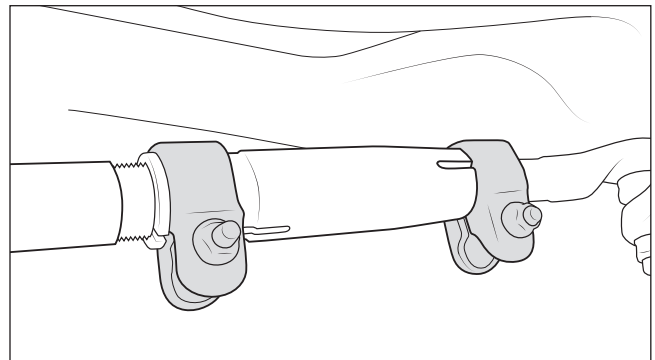

Figure 37



20. Bleed brakes.

21. Install the wheels and tires.

Once the Rear Suspension is completed and the vehicle is on the ground at ride height, you will need to torque the following:

Front radius arm bolts at the frame end — **240 lb-ft**

Front track bar bolts — Frame side: **324 lb-ft**, Axle side: **285 lb-ft**